

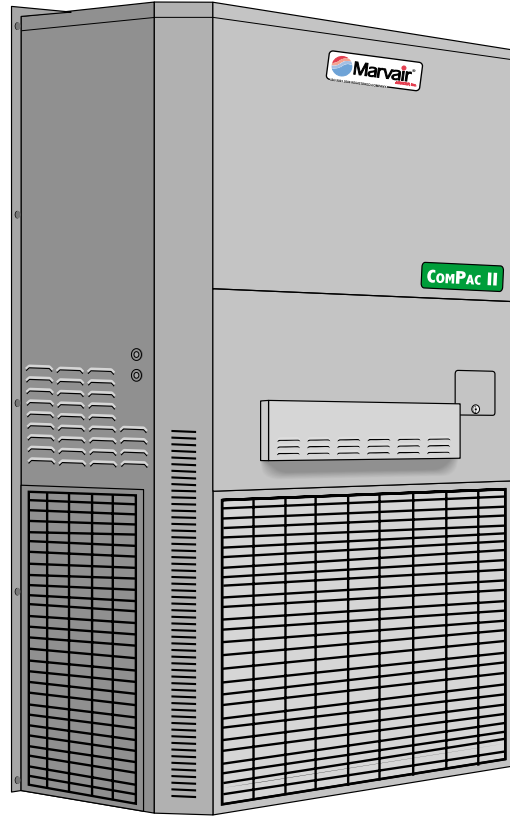

ComPac® I and ComPac® II Air Conditioner Product Manual

Vertical Wall-Mount Air Conditioners
with Front Control Box Panel
Models AVP20-24-30-36-42-48-60-72

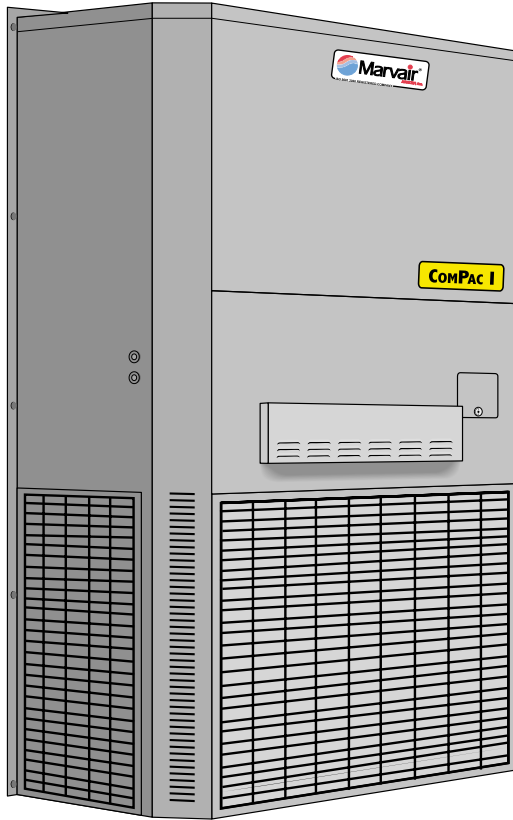

Description	5
Installation	22
Start-Up	39
Troubleshooting	41
Parts List	44
Maintenance	47
Warranty	48



Manufactured By:

Marvair® Division of AIRXCEL®, Inc.

P.O. Box 400 • Cordele, Georgia 31010
156 Seedling Drive • Cordele, Georgia 31015
(229) 273-3636 • Fax (229) 273-5154

E-mail: marvairtech@airxcel.com • Internet: www.marvair.com

P/81024 9/04-12
supersedes 11/03-11

How To Use This Manual

This manual is intended to be a guide to Marvair's ComPac® line of vertical air conditioners. It contains installation, troubleshooting, maintenance, warranty, and application information. The information contained in this manual is to be used by the installer as a guide only. This manual does not supersede or circumvent any applicable national or local codes.

If you are installing the ComPac® unit, first read Chapter 1 and scan the entire manual before beginning the installation as described in Chapter 2. Chapter 1 contains general, descriptive information and provides an overview which can speed up the installation process and simplify troubleshooting.

If a malfunction occurs, follow this troubleshooting sequence:

1. Make sure you understand how the ComPac® unit works (Chapters 1 & 3).
2. Identify and correct installation errors (Chapter 2).
3. Refer to the troubleshooting information in Chapter 4.

If you are still unable to correct the problem, contact the Factory at 1-800-841-7854 for additional assistance.

Please read the following “Important Safety Precautions” before beginning any work.

Important Safety Precautions

1. USE CARE when LIFTING or TRANSPORTING equipment.
2. TRANSPORT the UNIT UPRIGHT. Laying it down on its side may cause oil to leave the compressor and breakage or damage to other components.
3. TURN ELECTRICAL POWER OFF AT THE breaker or fuse box BEFORE installing or working on the equipment. LINE VOLTAGES ARE HAZARDOUS or LETHAL.
4. OBSERVE and COMPLY with ALL applicable PLUMBING, ELECTRICAL, and BUILDING CODES & ordinances.
5. SERVICE may be performed ONLY by QUALIFIED and EXPERIENCED PERSONS.
 - * Wear safety goggles when servicing the refrigeration circuit
 - * Beware of hot surfaces on refrigerant circuit components
 - * Beware of sharp edges on sheet metal components
 - * Use care when recovering or adding refrigerant
6. Use COMMON SENSE - BE SAFETY-CONSCIOUS

TABLE OF CONTENTS

ComPac® A/C Description & Specifications	
1.1	General Description 5
1.2	Model Identification 5
1.3	Serial Number Date Code 5
1.4	Ratings and Specifications 6
1.5	General Operation 9
1.6a	Electronic Control Board Mode of Operation 10
1.6b	Mechanical Controls 12
1.7	Optional Controls 12
1.8	Electrical Diagrams 14
1.9	Economizer Components 21
Installation	
2.1	Equipment Inspection 23
2.2	Installation Requirements 23
2.3	Installation Materials 24
2.4	Porting and Duct Work 26
2.5	Fresh Air Hood Installation 27
2.6	Bracket Installation 27
2.7	Mounting the Unit 27
2.8	Electrical Connections 28
Start-Up	
3.1	Check-Out of Cooling Cycle 33
3.2	Check-Out of Heating Cycle 33
3.3	A/C Testing with LL357D2 34
Troubleshooting	
4.1	Overview 35
4.2	Failure Symptoms Guide 36
4.3	Compressor Troubleshooting 37
4.4	Control Board Diagnosis 38
Parts List	
5.1	Parts List 39
5.2	Illustrations 40
Maintenance	
6.1	Scheduled Maintenance 42
Warranty	
7.1	Limited Product Warranty 43
7.2	Optional Silver Service Program 44

ILLUSTRATIONS

Figure 1a.	ComPac® I & II A/C Dimensions - Models 20-36	7
1b.	ComPac® I & II A/C Dimensions - Models 42-60	7
1c.	ComPac® I & II A/C Dimensions - Model 72	8
Figure 2.	Refrigerant Circuit	9
Figure 3a.	Typical Electrical Schematic-ComPac® IA/C Models 20-60 with Mechanical Relays and Contactors	15
3b.	Typical Electrical Schematic-ComPac® IA/C Models 20-60 with Electronic Control Board	16
3c.	Typical Electrical Schematic-ComPac® II A/C Models 20-60 with Mechanical Relays and Contactors	17
3d.	Typical Electrical Schematic-ComPac® II A/C Models 20-60 with Electronic Control Board	18
3e.	Typical Electrical Schematic-ComPac® IA/C Model 72	19
3f.	Typical Electrical Schematic-ComPac® II A/C Model 72	20
Figure 4.	H205A Temperature Control Points	21
Figure 5.	H205A Control Point Adjustment	22
Figure 6.	Fresh Air Hood Installation	27
Figure 7.	Wall Mounting Detail - ComPac® A/C AVP20-72	28
Figure 8a.	Thermostat Wiring Details	31
Figure 8b.	CommStat 3™ Wiring Detail	31
Figure 8c.	LL357D2 Wiring Detail	32

TABLES

Table 1	CFM @ External Static Pressure	6
Table 2	Ship Weight	6
Table 3	Standard Filter Size	6
Table 4	Minimum Clearances	24
Table 5	Voltage Limitations	24
Table 6	Maximum Static Pressure	26

DESCRIPTION & SPECIFICATIONS

1.1 GENERAL DESCRIPTION

Marvair's ComPac® lines are a series of vertical wall-mounted air conditioning systems that provide heating, cooling, and ventilation for electronic equipment shelters, process control centers, and other applications with high internal heat gains. The series includes multiple sizes and nominal cooling capacities from 18,000 to 72,000 BTUH. Resistance heating elements are available in various wattages.

Marvair's ComPac® I & ComPac® II air conditioners, models AVP20-60, feature an exclusive electronic control board. The control board consolidates several of the electrical components and improves the air conditioner's reliability. The control board replaces the blower relay, the lockout relay, the compressor time delay and the timed low pressure bypass. In addition, the control board has LED's to indicate operating status and fault conditions to assist the service technician. A complete description of functions of the control board is in Section 1.6. The AVP72 does not currently have the control board.

The ComPac® I & ComPac® II models are designed for easy installation and service. Major components are accessible for service beneath external panels.

All units have internal disconnects (optional on 460V). Depending upon state and local code requirements, this feature may eliminate the need for an external breaker or disconnect.

The ComPac® IA/C has a 0-15% manual outside air damper and the ComPac® II A/C has a factory installed economizer for 100% free cooling with outside air.

1.2 MODEL IDENTIFICATION

The model identification number is found on the data sticker. Rating plate located on side panel.

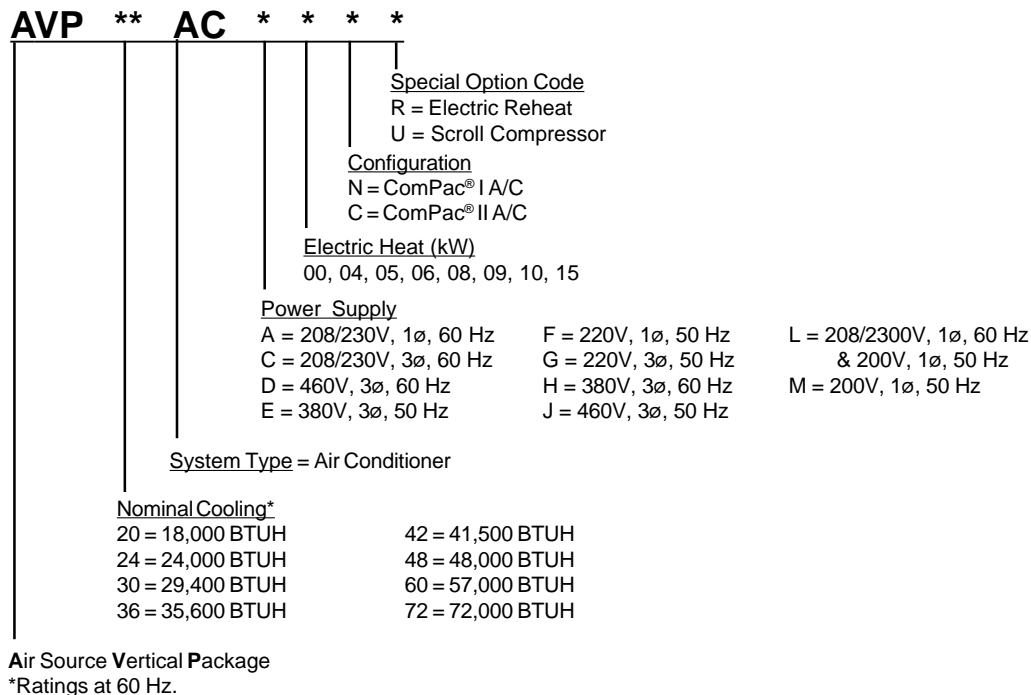

1.3 SERIAL NUMBER DATE CODE

A = January	E = May	J = September	L = 2000	R = 2004	V = 2008
B = February	F = June	K = October	M = 2001	S = 2005	W = 2009
C = March	G = July	L = November	N = 2002	T = 2006	
D = April	H = August	M = December	P = 2003	U = 2007	

1.4 RATINGS & SPECIFICATIONS

MODEL	0.10	0.20	0.25	0.30	0.40	0.50
20	860	810	740	670		
24	860	810	740	670		
30	1100	1000	960	920	810	
36	1310	1220	1185	1150	1060	
42		1650	1585	1520	1450	1360
48		1900	1830	1760	1700	1620
60		1900	1830	1760	1700	1620
72		2100	1950	1800	1730	1660

Table 1. CFM @ External Static Pressure (Wet Coil) (IWG)

MODEL	20/24 LBS/KG	30/36 LBS/KG	42 LBS/KG	48 LBS/KG	60 LBS/KG	72 LBS/KG
COMPAC® I A/C	274/125	355/160	495/225	521/240	535/245	600/272
COMPAC® II A/C	286/130	365/170	527/240	552/250	565/260	640/290

Table 2. Ship Weight

MODEL	20/24	30/36	42/48/60	72
FILTER SIZE (inches)	16 x 25 x 2	16 x 30 x 2	22 x 36-1/2 x 2	18 x 24 x 2*
FILTER SIZE (mm)	406 x 635 x 51	406 x 762 x 51	559 x 927 x 51	452 x 610 x 51

* Two filters required.

Table 3. Filter Size

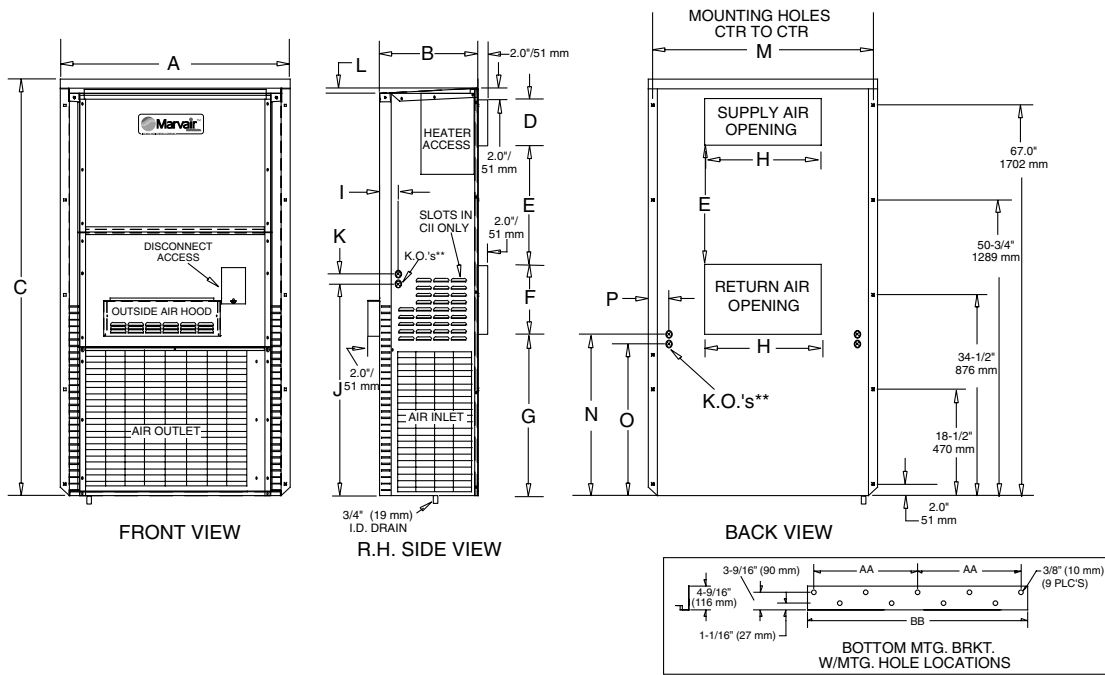

MODEL	A	B	C	D	E	F	G	H	I	J	K	L	M	N	O	P	AA	BB
20/24	39-1/2	17-1/4	71-1/2	8	20-1/2	12	27-11/16	20	3-3/4	36-5/16	1-11/16	7/8	38	27-11/16	26	3-5/8	17-5/8	35-1/4
30/36	44-9/16	17-1/4	71-1/2	8	18	14	28-7/16	28	3-3/4	36-5/16	1-11/16	7/8	43-1/8	27-11/16	26	3-5/8	20-1/4	40-1/2

NOTE: Dimensional tolerance $\pm 1/16"$

Figure 1a. ComPac® I & ComPac® II A/C Dimensions- Models AVP20-36 (in inches)

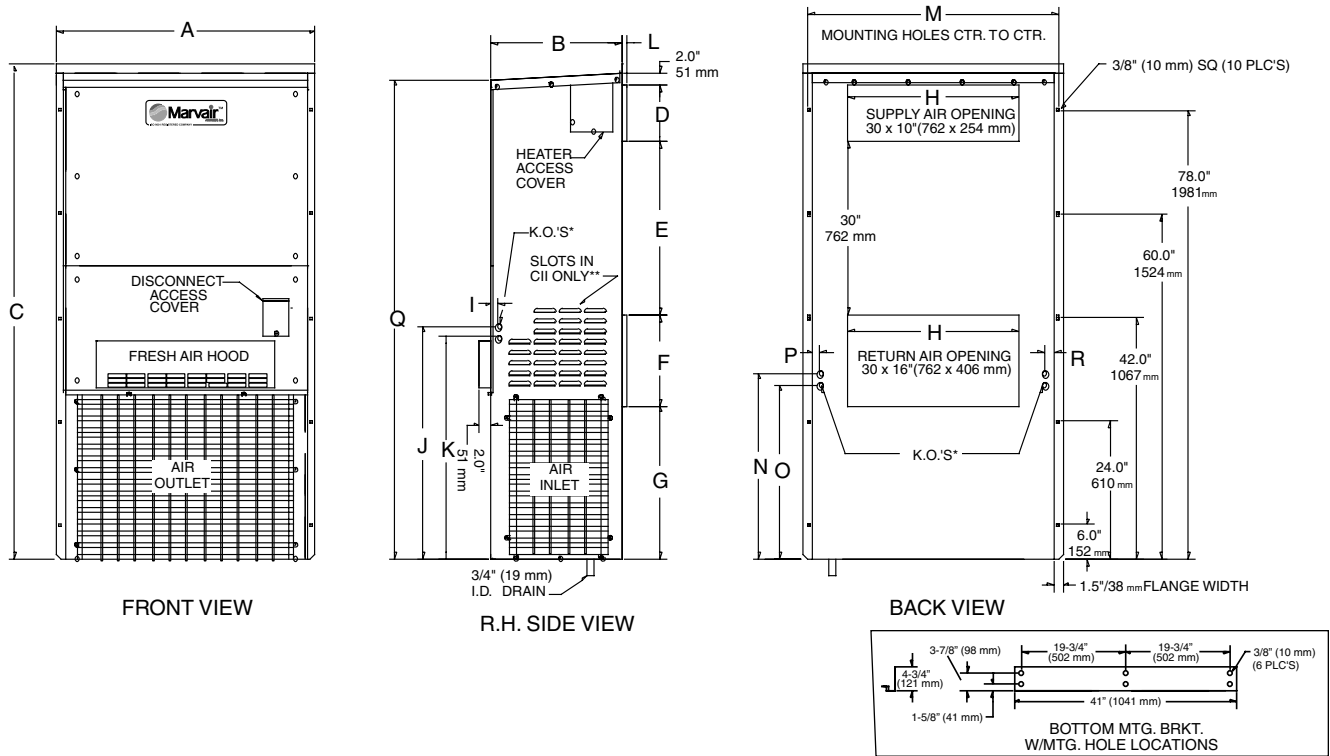

MODEL	A	B	C	D	E	F	G	H	I	J	K	L	M	N	O	P	Q	R
42/48/60	45	22-5/8	86	10	30	16	26-1/2	30	1-5/16	40-9/16	38-9/16	1-1/8	43-1/2	32-3/8	30-3/8	1-1/4	83-5/16	1-3/4

NOTE: Dimensional tolerance $\pm 1/16"$

Figure 1b. ComPac® I A/C & ComPac® II A/C Dimensions- Models AVP42-60 (in inches)

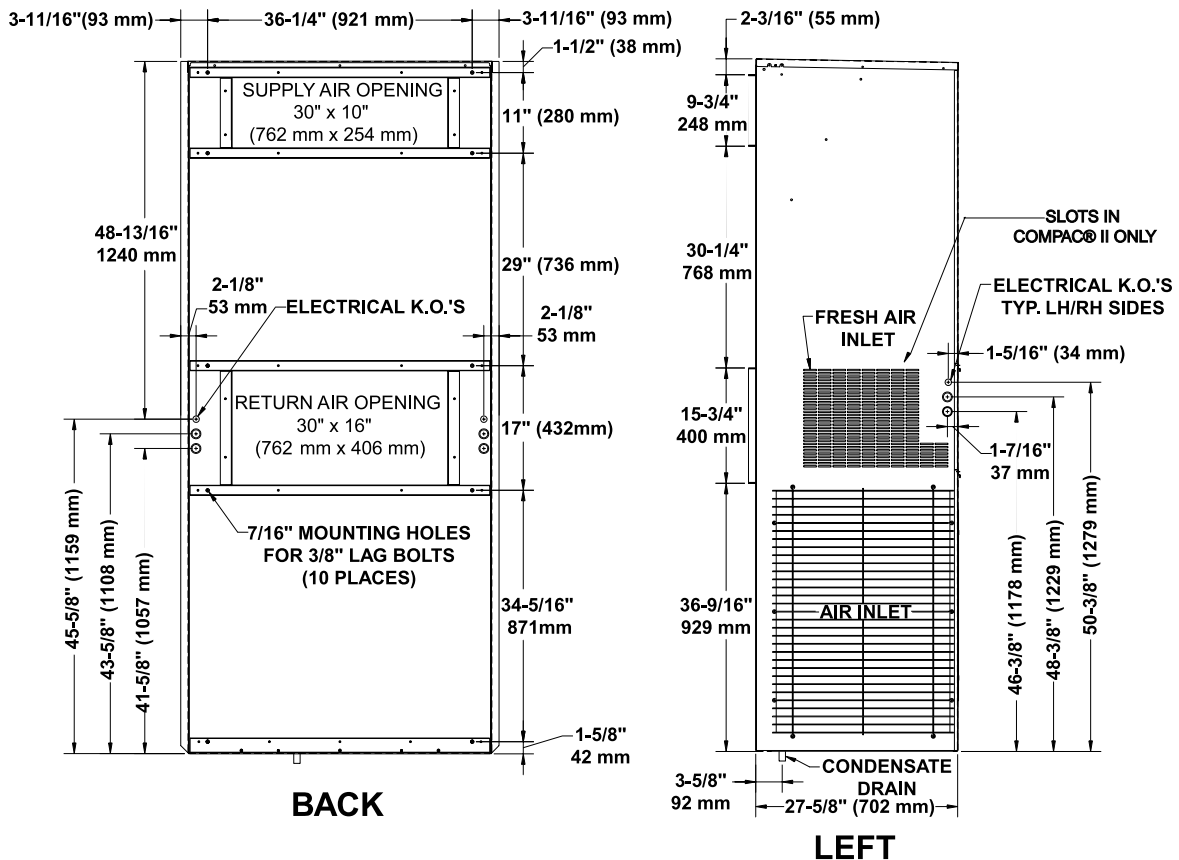
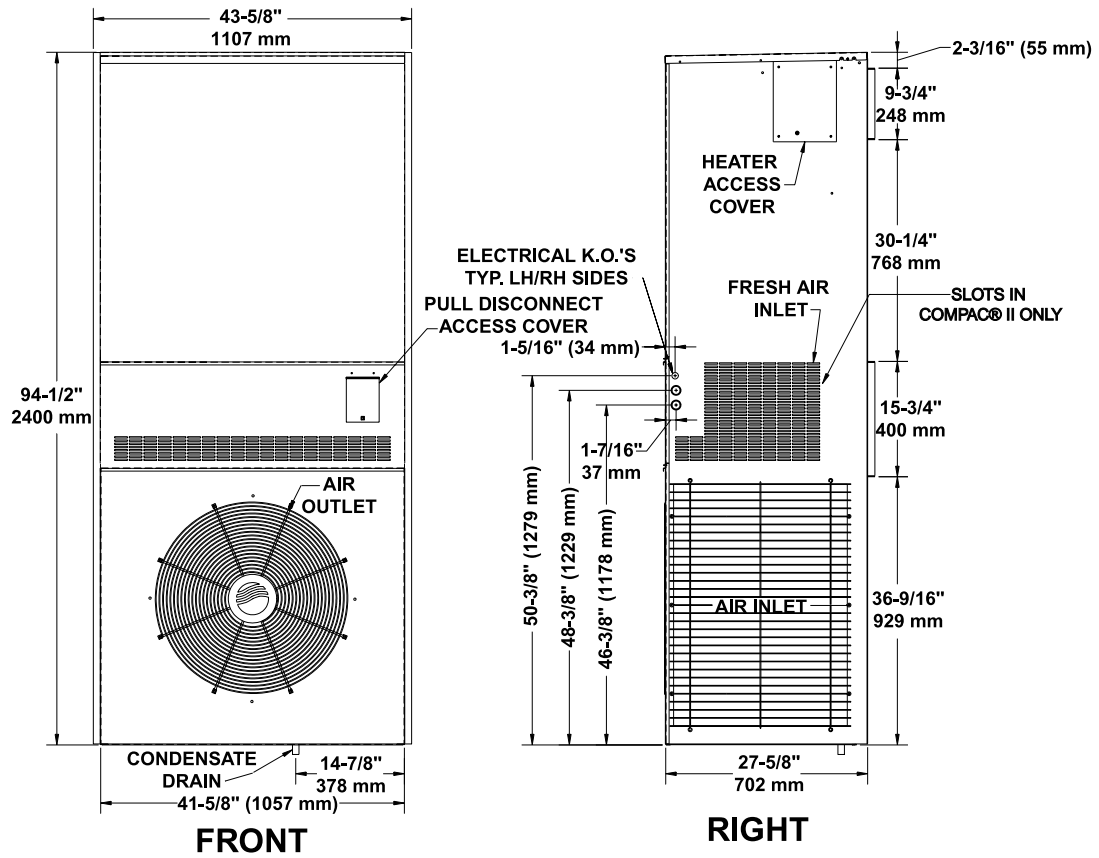

Figure 1c. ComPac® I A/C & ComPac® II A/C Dimensions- Models AVP72 (in inches & mm)

1.5 GENERAL OPERATION

Refrigerant Cycle (Cooling Mode)

The ComPac® I & ComPac® II A/C use R-22 refrigerant in a conventional vapor-compression refrigeration cycle to transfer heat from air in an enclosed space to the outside. A double blower assembly blows indoor air across the evaporator. Cold liquid refrigerant passing through the evaporator is boiled into gas by heat removed from the air. The warmed refrigerant gas enters the compressor where its temperature and pressure are increased. The hot refrigerant gas condenses to liquid as heat is transferred to outdoor air drawn across the condenser by the condenser fan. Liquid refrigerant is metered into the evaporator through capillary tubes to repeat the cycle.

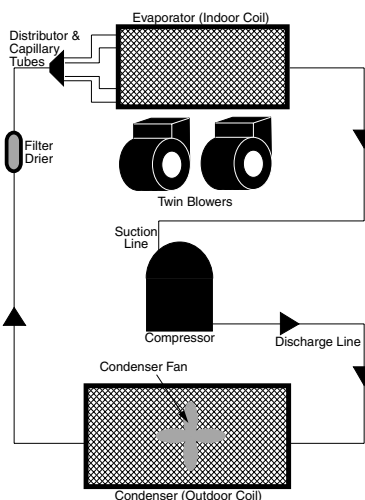

Figure 2. Refrigerant Circuit

Heating Mode

A wall-mounted thermostat controls the heating cycle of models which incorporate resistance heating elements. On a call for heat, the thermostat closes the heat relay to energize the indoor fan and the resistance elements. Except on units with the optional dehumidification kit, the compressor is locked out during the heating cycle.

Economizer Operation (ComPac® II A/C Only)

The economizer is a regulated damper system with controls. The damper regulates the circulation of outside air into the enclosure (when the outdoor air conditions are suitable) to reduce the need for mechanical cooling, save energy, and extend compressor life.

Depending upon the options selected, the damper responds to the enthalpy of the outdoor air. On a call for cooling from a space thermostat, it operates as follows:

When the enthalpy of the outdoor air is below the set point, the outdoor air damper is proportioned open (and return air damper is proportioned closed) to maintain between 50°F and 56°F at the mixed/discharge air sensor.

When the enthalpy of the outdoor air is above the set point, the outdoor air damper closes to its minimum position. A call for cooling from the space thermostat brings on mechanical cooling.

An optional built-in adjustable minimum position potentiometer (part number 70012) controls the amount of outdoor air admitted to meet minimum ventilation requirements.

**1.6A ELECTRONIC
CONTROL BOARD
MODE OF
OPERATION
(AVP20-60)
(SEE SECTION 1.6B
FOR MECHANICAL
CONTROLS)**

Normal

24 VAC power must be continuously applied to “R” and “C”. Upon a call for cooling “Y” and with the high pressure switch (HPS) closed, the compressor will be energized. (Note: See the delay on make feature.) The compressor will remain energized during the 3 minute timed low pressure by-pass cycle, if the low pressure switch (LPS) is open the compressor will de-energize.

Lock-out

If either of the fault conditions (LPS or HPS) occurs twice, the control board will enter into and indicate the lockout mode. In the lockout mode, the compressor is turned off. If there is a call for indoor air flow “G”, the blower remains energized, the alarm output is energized and the status led will blink to indicate which fault has occurred. When the lockout condition is cleared, the unit will reset if the demand for the thermostat is removed or when the power is reset. With the control board, the user can now have normally closed contacts by moving a wire on the control board. The ComPac® air conditioners are factory wired to be normally open.

Delay on Break

If the compressor is de-energized due to a loss of a cooling “Y” call or the first fault, the unit re-start will be delayed 3 minutes from the time the contactor is de-energized. (Note: There is no delay on break if the lockout condition is reset.)

Delay on Make

On initial power up only, the unit will wait 0.03 to 10 minutes from the cooling “Y” call before allowing the contactor to energize. The delay can be adjusted by the DOM wheel on the board. Factory recommended wait is 3 minutes.

Low Pressure By-Pass Time

While running or starting, the low pressure switch (LPS) fault condition will be by-passed for 3 minutes before de-energizing the contactor.

Post Purge

Upon a call for indoor airflow “G” the blower will energize immediately. When in the cooling mode, the blower will remain energized for 10 to 90 seconds (adjustable) after the compressor has been de-energized. The time period can be changed by fan purge wheel on the board. Factory setting is 90 seconds.

LED Indicator Lights

COLOR	TYPE	STATUS	DESCRIPTION
Green	Power	Constant On	24 VAC power has been applied
		Constant On	Normal operation
		1 Blink	High pressure switch has opened twice
Red	Status	2 Blinks	Low pressure switch has opened twice

Low Ambient Control

The low ambient control permits cooling when outdoor ambient temperatures are low. The control uses a reverse-acting high pressure switch to cycle the condenser fan motor according to liquid refrigerant pressure conditions. Switch closure and fan operation occurs when the pressure reaches 250 PSIG. The switch opens again when the refrigerant pressure falls to 190 PSIG. Therefore, the outdoor fan always starts after the compressor, and **it will cycle frequently during normal operation at low outdoor conditions.**

High Pressure Switch

The high pressure switch is mounted on the compressor discharge line. It is electrically connected to a lockout relay which shuts down the system if the refrigerant pressure rises to 400 PSIG (AVP60 setting is 450 PSIG). This protects the unit if airflow through the condenser is blocked or if the outdoor fan motor fails.

Although the contacts of the high pressure switch close when the refrigerant pressure falls to approximately 300 PSIG, the system must be manually reset once the lockout relay is activated. A manual reset is necessary to prevent harmful short-cycling. To reset switch, turn primary power off, then back on or turn thermostat system switch off, then back on.

Low Pressure Switch

The low pressure switch is mounted on the compressor suction line. It is designed to open if the refrigerant pressure drops to 35 PSIG; it resets when the pressure rises to 60 PSIG. The switch protects the unit if airflow through the indoor blower is impeded, if the blower motor fails, or if there is a loss of refrigerant.

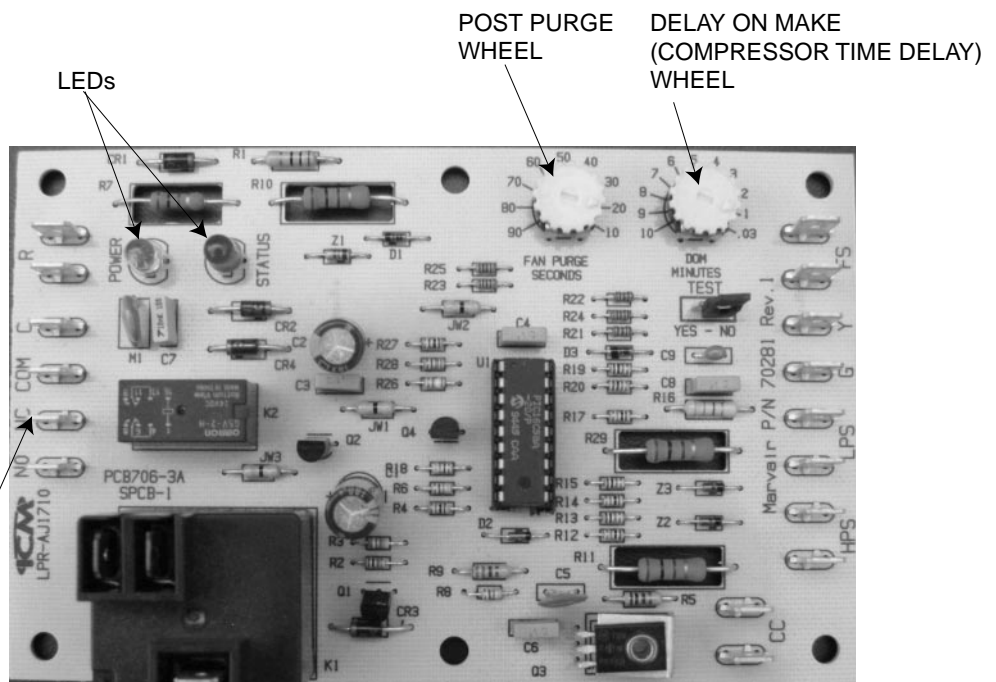

MOVE WIRE FROM NORMALLY OPEN TERMINAL TO NORMALLY CLOSED IF NORMALLY CLOSED IS DESIRED

1.6B MECHANICAL CONTROLS (AVP20-72)

Time Delay/Anti-Short Cycle Timer

The time delay (delay on make) prevents the compressor from restarting immediately after interruption of power. The delay interval, which is adjustable from .2 to 10 minutes (factory set at 3 minutes), protects the compressor by allowing internal refrigerant pressures to equalize. For dual units, set one timer at 3 minutes and the other at 5 minutes.

The time delay does not effect the electric heat circuit.

Low Ambient Control

The low ambient control permits cooling when outdoor ambient temperatures are low. The control uses a reverse-acting high pressure switch to cycle the condenser fan motor according to liquid refrigerant pressure conditions. Switch closure and fan operation occurs when the pressure reaches 250 PSIG. The switch opens again when the refrigerant pressure falls to 190 PSIG. Therefore, the outdoor fan always starts after the compressor, and **it will cycle frequently during normal operation at low outdoor conditions.**

High Pressure Switch

The high pressure switch is mounted on the compressor discharge line. It is electrically connected to a lockout relay which shuts down the system if the refrigerant pressure rises to 400 PSIG. This protects the unit if airflow through the condenser is blocked or if the outdoor fan motor fails.

Although the contacts of the high pressure switch close when the refrigerant pressure falls to approximately 300 PSIG, the system must be manually reset once the lockout relay is activated. A manual reset is necessary to prevent harmful short-cycling. To reset switch, turn primary power off, then back on or turn thermostat system switch off, then back on.

Low Pressure Switch

The low pressure switch is mounted on the compressor suction line. It is designed to open if the refrigerant pressure drops to 35 PSIG; it resets when the pressure rises to 60 PSIG. The switch protects the unit if airflow through the indoor blower is impeded, if the blower motor fails, or if there is a loss of refrigerant.

Lock-Out Relay

The lockout relay prevents the unit from cycling on the pressure switch by providing positive shutdown if the high pressure limit is exceeded. An extra set of dry contacts (normally open) on the relay (Figure 8) may be used for signaling a lockout condition. Once triggered, the relay must be manually reset.

Timed Low Pressure By-Pass

The timed safety bypass provides a current path around the low pressure switch following each start for a period of one to three minutes. This bypass is essential when operating mechanical cooling when ambient temperatures are less than 20°F (-6°C).

Hard Start Kit

Used on single phase equipment to give the compressor higher starting torque under low voltage conditions. Generally not recommended on units with scroll compressors.

Extreme Duty Package

The Extreme Duty Package allows selected Marvair® ComPac® I & ComPac® II air conditioners to operate in extremely cold and hot ambient conditions. The Extreme Duty Kit

1.7 OPTIONAL CONTROLS & PACKAGES

is always factory installed and is available on all ComPac® air conditioners. ComPac® I air conditioners (non-economizer units) will operate from 0° F to 130° F (-18° to 54°C). ComPac® II air conditioners (economizer units) will operate from -20° F to 130° F (-29° to 54°C).

The Extreme Duty Package includes a suction line accumulator, thermal expansion valve (TXV), crankcase heater, hard start kit, an auto reset, adjustable high pressure switch and an outdoor thermostat and fan cycle switch. The fan cycle control is standard on all ComPac® air conditioners and operates based upon the liquid line pressure. The outside thermostat opens whenever the outside temperature is below 50° F (10°C) and closes when the outside temperature is 50° F (10°C) or higher. Whenever the temperature is below 50° F (10°C), the fan cycle switch is in the circuit; when temperatures are 50° F (10°C) or higher, the fan cycle switch is not in the circuit. The outdoor thermostat is used with a TXV to prevent excessive cycling or "hunting" of the TXV.

Coastal Environmental (ComPac® IA/C Only)

Recommended for units to be installed near an ocean or on seacoast. Includes stainless steel fasteners, sealed condenser fan motor, sealed control box, protective coating applied to all exposed internal copper in the condenser section and a phenolic or impregnated polyurethane coating on the condenser coil.

Stainless Steel Cabinet (ComPac® IA/C Only)

All sheet metal constructed of stainless steel.

Hot Gas Bypass (ComPac® IA/C Only)

Used in specialty applications; i.e., Magnetic Resonance Imaging (MRI) buildings, to prevent magnetic voltage disturbance caused by compressor cycling. Two hot gas bypass option packages are available to allow operation to 20° F (-7°C) or minus 20° F (-29°C). Please refer to Hot Gas Bypass Application Bulletin for details.

Electric Reheat Dehumidification

A humidity controller (p/n 50057) allows electric heat and cooling to operate simultaneously. Marvair® air conditioners equipped with the dehumidification option allow the indoor humidity of the controlled environment to be maintained at or below a certain humidity set point. These units do not have the ability to add humidity to the building.

IMPORTANT: The electrical wire and breaker or fuses must be sized for simultaneous operation of the electric heater and the air conditioner. Refer to the data sticker on the unit or the ComPac® Air Conditioner Product Data Sheet for the sizing information.

Dehumidification is achieved by operating mechanical cooling in conjunction with electric reheat. The strip heat is sized approximately to the sensible capacity of the total tonnage of the machine (i.e., on a 24,000 BTU unit the strip heat is sized at approximately 20,000 BTU). Because the strip heat is sized to the approximate sensible cooling capacity, only selected models are available.

Operation:

When the humidity rises above the set point on the humidity controller both mechanical cooling and electric reheat operate to temper the air and lower the humidity. If the temperature in the controlled environment rises above the set point of the thermostat and the unit is operating in

the dehumidification mode, the call for cooling will override the call for dehumidification and the strip heat is disengaged until the thermostat is satisfied. This assures the environment temperature is maintained as first priority and humidity control is second.

In applications where a shelter has redundant air conditioning units and is controlled by a lead lag controller (Marvair's LL357D2 or CommStat3™ Controller), most times the dehumidification option is only necessary on one of the two units. It is possible for one unit to be operating in the cooling mode while the unit with dehumidification is operating at the same time. If the cooling unit does not maintain the shelter temperature set point, the unit with dehumidification will go into the cooling mode. It does not matter whether the unit with dehumidification is the lead or lag unit.

Three Phase Voltage Monitor, Marvair® P/N 51394

Continuously measures the voltage of each of the three phases. The monitor separately senses low and high voltage, voltage unbalance including phase loss and phase reversal. An LED indicator glows when all voltages are acceptable. Automatically resets when voltages and phases are within operating tolerances.

Dirty Filter Indicators

Two types of dirty filter indicators are available from Marvair®. A flag type detects a reduction of air flow on the discharge side of the filter. When a reduction in air flow is detected, a signal is sent to a set of dry contacts. For more reliable, precise indication of a dirty filter, a diaphragm type of indicator should be used. This type measures the air pressure on either side of the filter and when the pressure drops below the set point, a signal is sent to a set of dry contacts. The set point is adjustable.

Minimum Potential Potentiometer

Used in the ComPac® II units with the factory installed economizer. The potentiometer prevents the economizer from closing completely, assuring that outside air will be brought into the shelter and exhausted whenever the indoor blower is operating. This provides position pressurization of the building. The minimum potential potentiometer is adjustable.

1.8 ELECTRICAL DIAGRAMS

The compressor and condenser fan are energized with a contactor controlled by a 24 VAC pilot signal.

Some compressors incorporate an internal PTC crankcase heater that functions as long as primary power is available. The heater drives liquid refrigerant from the crankcase and prevents loss of lubrication caused by oil dilution. Power must be applied to the unit for 24 hours before starting the compressor.

The condenser (outside fan) motor is energized by the same contactor. However, the motor is cycled on and off by the low ambient control (see low ambient control 1.6a and 1.6b).

The indoor evaporator fan motor is cycled by the blower timed delay relay.

CAUTION: ELECTRICAL SHOCK HAZARD
DISCONNECT POWER BEFORE SERVICING

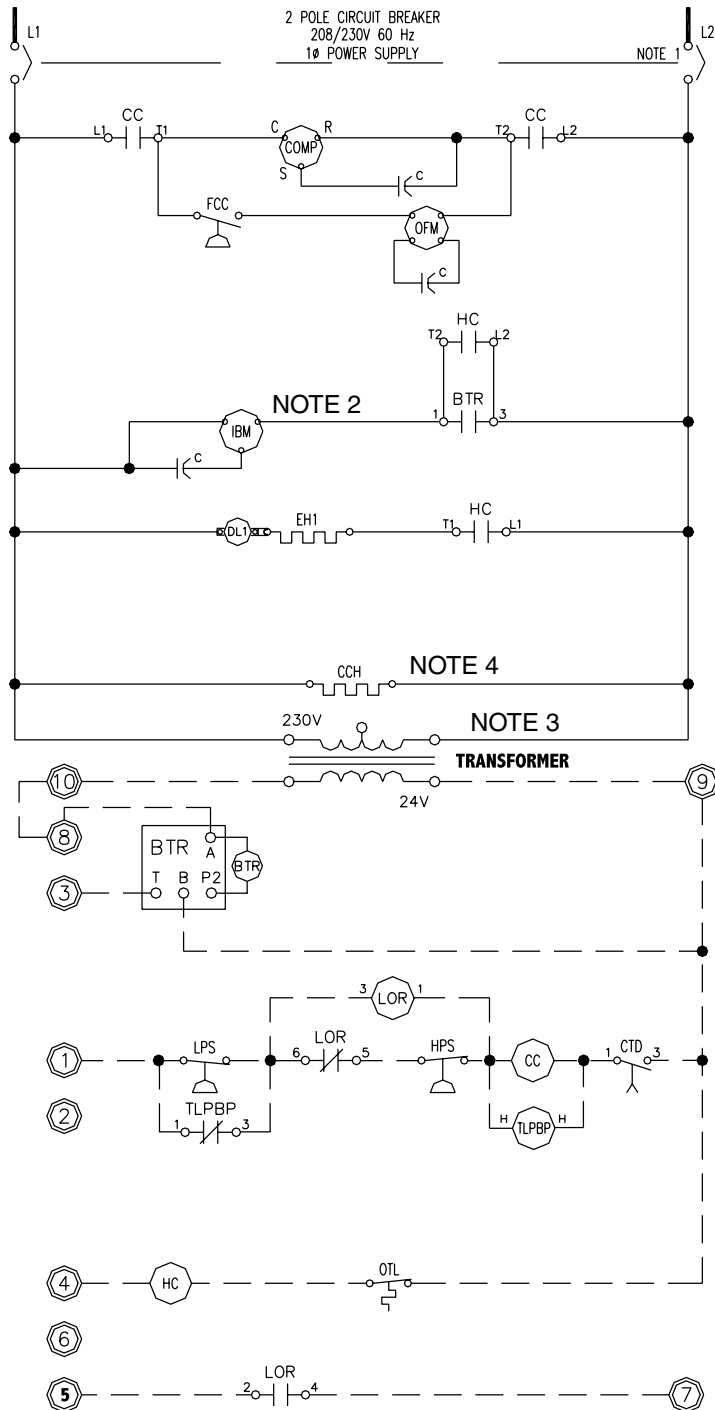

ELECTRICAL LEGEND:

BTR	BLOWER TIME RELAY
C	CAPACITOR
CC	COMPRESSOR CONTACTOR
CCH	CRANKCASE HEATER
COMP	COMPRESSOR
CTD	COMPRESSOR TIME DELAY
DL	DUAL LIMIT
EH	ELECTRIC STRIP HEATER
FCC	FAN CYCLE CONTROLLER
HPS	HIGH PRESSURE SWITCH
HC	HEAT CONTACTOR
IBM	INDOOR BLOWER MOTOR
LOR	LOCK-OUT RELAY
LPS	LOW PRESSURE SWITCH
OFM	OUTDOOR FAN MOTOR
OTL	ONE TIME LIMIT
TLPBP	TIMED LOW PRESSURE BYPASS
XFMR	TRANSFORMER

VOLTAGE LEGEND

—————	LINE VOLTAGE FACTORY
—————	LINE VOLTAGE FIELD
- - - - -	LOW VOLTAGE FACTORY
—————	LOW VOLTAGE FIELD
—————	ALT. VOLTAGE (FIELD SPEC.)

COLOR CODE

BK - BLACK	O - ORANGE
BL - BLUE	R - RED
BR - BROWN	Y - YELLOW
G - GREEN	WHT - WHITE
BK/RED - BLACK, RED STRIPE	

GENERAL NOTES:

1. 208/230 VOLT 60 HZ, 1 PH POWER SUPPLY. SEE DATA PLATE FOR AMPACITY & FUSE SIZE. DISCONNECT SHOWN.
2. SPEED TAP FOR MULTISPEED MOTORS - SEE MOTOR NAMEPLATE FOR WIRE COLOR.
3. TRANSFORMER IS FACTORY WIRED FOR 230 VOLT OPERATION. FOR LOWER VOLTAGES, INTERCHANGE ORANGE AND RED LEADS. INSULATE UNUSED LEADS.
4. OPTIONAL CRANKCASE HEATER SHOWN. STANDARD ON RECIPROCATING COMPRESSORS.

Figure 3a. Typical Electrical Schematic - ComPac® I A/C, Models AVP20-60 with Mechanical Relays and Contactors

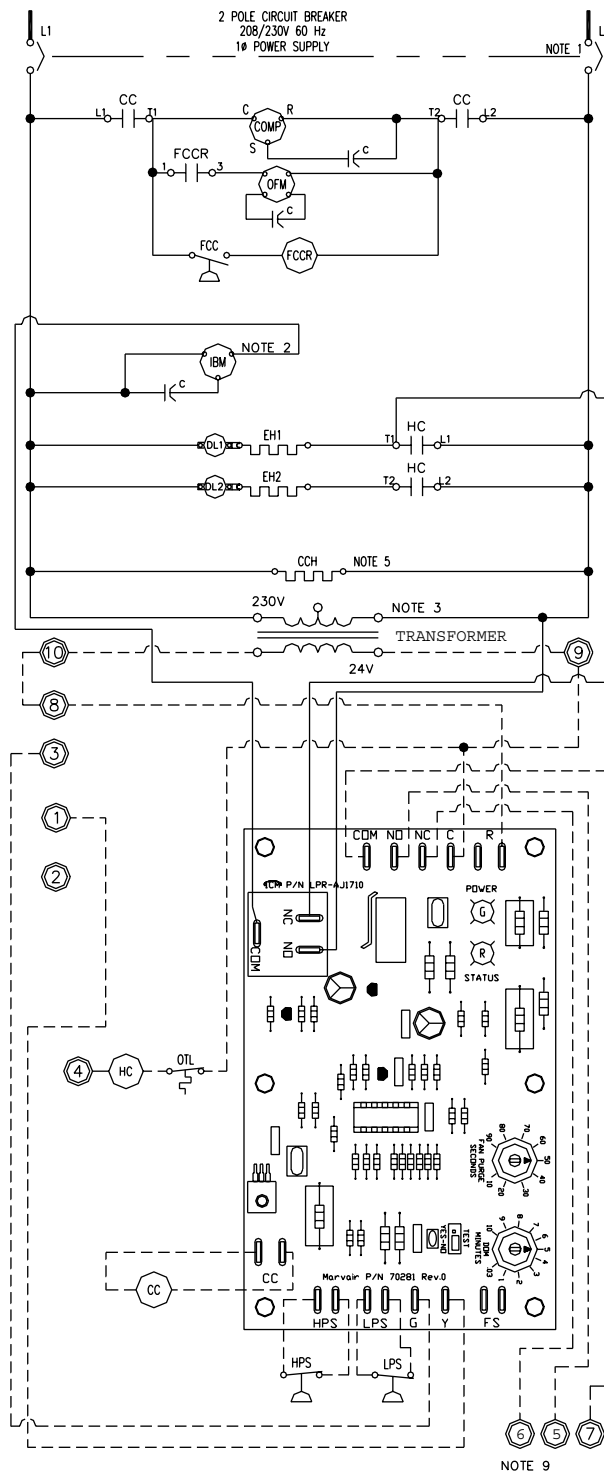

- VOLTAGE LEGEND**
- LINE VOLTAGE FACTORY
 - LINE VOLTAGE FIELD
 - - - - - LOW VOLTAGE FACTORY
 - - - - - LOW VOLTAGE FIELD
 - - - - - ALT. VOLTAGE (FIELD SPEC.)
- COLOR CODE**
- | | |
|----------------------------|-------------|
| BK - BLACK | O - ORANGE |
| BL - BLUE | R - RED |
| BR - BROWN | Y - YELLOW |
| G - GREEN | WHT - WHITE |
| BK/RED - BLACK, RED STRIPE | |
- ELECTRICAL LEGEND:**
- | | | | |
|------|-------------------------|------|-----------------------|
| C | CAPACITOR | OFM | OUTDOOR FAN MOTOR |
| CC | COMPRESSOR CONTACTOR | OTL | ONE TIME LIMIT |
| CCH | CRANKCASE HEATER | PCB | PRINTED CIRCUIT BOARD |
| COMP | COMPRESSOR | XFMR | TRANSFORMER |
| DL | DUAL LIMIT | | |
| EH | ELECTRIC STRIP HEATER | | |
| FCC | FAN CYCLE CONTROLLER | | |
| FCCR | FAN CYCLE CONTROL RELAY | | |
| HPS | HIGH PRESSURE SWITCH | | |
| HC | HEAT CONTACTOR | | |
| IBM | INDOOR BLOWER MOTOR | | |
| LPS | LOW PRESSURE SWITCH | | |

GENERAL NOTES:

1. 208/230 VOLT 60 Hz 1Ø POWER SUPPLY. SEE DATA PLATE FOR AMPACITY & FUSE SIZE. OPTIONAL CKT BKR SHOWN.
2. SPEED TAP - SEE MOTOR NAMEPLATE FOR WIRE COLOR.
3. TRANSFORMER IS FACTORY WIRED FOR 230 VOLT OPERATION. FOR LOWER VOLTAGES, INTERCHANGE ORANGE AND RED LEADS. INSULATE UNUSED LEADS.
4. ALTERNATE DEVICE IS NOT ADJUSTABLE AND HAS ORANGE LEADS.
5. CRANKCASE HEATER MAY NOT BE REQUIRED ON ALL COMPRESSORS.
6. PTCR IS NOT REQUIRED ON ALL COMPRESSORS.
7. COMPRESSOR TIME DELAY AND FAN PURGE DELAY ARE LOCATED ON THE PCB (PRINTED CIRCUIT BOARD) AND ARE ADJUSTABLE.
8. THE (STATUS LED) WILL BLINK ONE TIME AFTER THE HPS (HIGH PRESSURE SWITCH) HAS OPENED TWICE AND THE UNIT WILL LOCKOUT. THE (STATUS LED) WILL BLINK TWICE AFTER THE LPS (LOW PRESSURE SWITCH) HAS OPENED TWICE AND THE UNIT WILL LOCKOUT.
9. THE LOCKOUT CIRCUIT CONTACTS ARE N.O. BETWEEN TERMINALS 5 AND 7 OF THE LOW VOLTAGE TERMINAL BOARD AND N.C. BETWEEN TERMINALS 7 AND 6 OF THE LOW VOLTAGE TERMINAL BOARD.

Figure 3b. Typical Electrical Schematic - ComPac® I A/C, Models AVP20-60 with Electronic Control Board

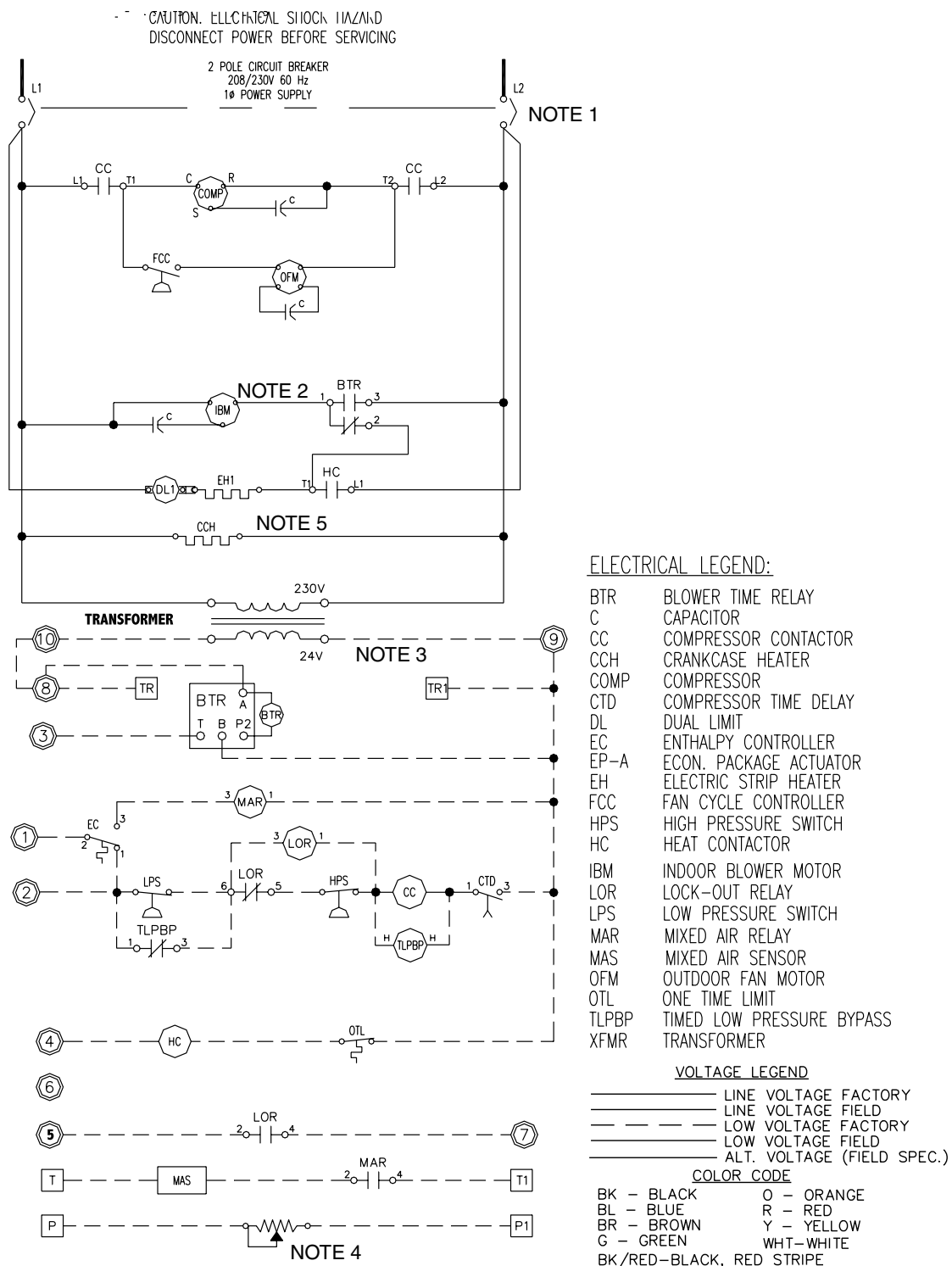

- GENERAL NOTES:**
1. 208/230 VOLT 60 HZ, 1 PH POWER SUPPLY. SEE DATA PLATE FOR AMPACITY & FUSE SIZE. DISCONNECT SHOWN.
 2. SPEED TAP FOR MULTISPEED MOTORS - SEE MOTOR NAMEPLATE FOR WIRE COLOR.
 3. TRANSFORMER IS FACTORY WIRED FOR 230 VOLT OPERATION. FOR LOWER VOLTAGES, INTERCHANGE ORANGE AND RED LEADS. INSULATE UNUSED LEADS.
 4. OPTIONAL FIELD INSTALLED 270 OHM MINIMUM POSITION POTENTIOMETER.
 5. CRANKCASE HEATER SHOWN. STANDARD ON RECIPROCATING COMPRESSORS.

Figure 3c. Typical Electrical Schematic - ComPac® II A/C, Models AVP20-60 with Mechanical Relays and Contactors

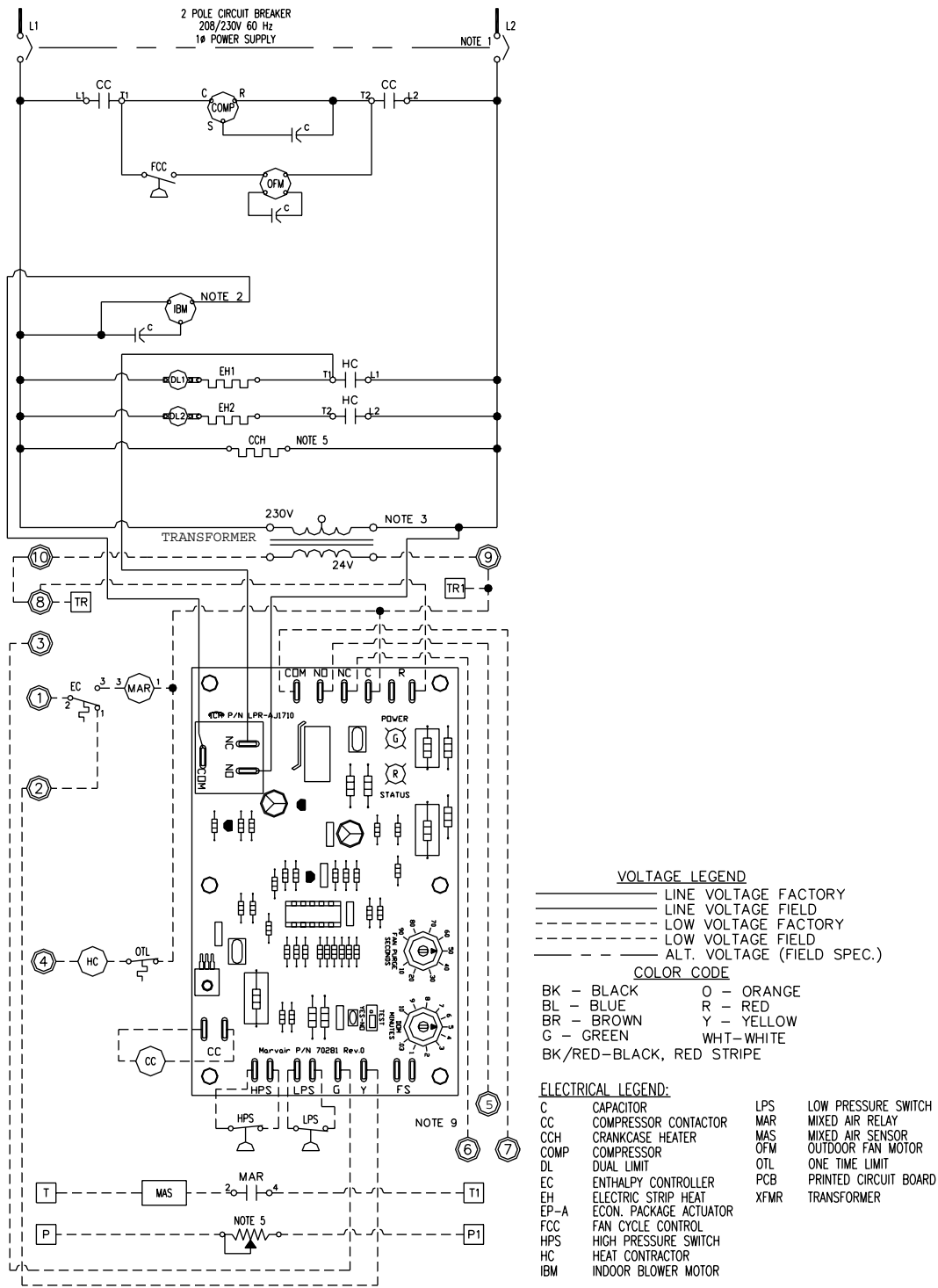

GENERAL NOTES:

1. 208/230 VOLT 60 Hz 1Ø POWER SUPPLY. SEE DATA PLATE FOR AMPACITY & FUSE SIZE. OPTIONAL CKT BKR SHOWN.
2. SPEED TAP - SEE MOTOR NAMEPLATE FOR WIRE COLOR.
3. TRANSFORMER IS FACTORY WIRED FOR 230 VOLT OPERATION. FOR LOWER VOLTAGES, INTERCHANGE ORANGE AND RED LEADS. INSULATE UNUSED LEADS.
4. ALTERNATE DEVICE IS NOT ADJUSTABLE AND HAS ORANGE LEADS.
5. CRANKCASE HEATER MAY NOT BE REQUIRED ON ALL COMPRESSORS.
6. PTCR IS NOT REQUIRED ON ALL COMPRESSORS.
7. COMPRESSOR TIME DELAY AND FAN PURGE DELAY ARE LOCATED ON THE PCB (PRINTED CIRCUIT BOARD) AND ARE ADJUSTABLE.
8. THE (STATUS LED) WILL BLINK ONE TIME AFTER THE HPS (HIGH PRESSURE SWITCH) HAS OPENED TWICE AND THE UNIT WILL LOCKOUT. THE (STATUS LED) WILL BLINK TWICE AFTER THE LPS (LOW PRESSURE SWITCH) HAS OPENED TWICE AND THE UNIT WILL LOCKOUT.
9. THE LOCKOUT CIRCUIT CONTACTS ARE N.O. BETWEEN TERMINALS 5 AND 7 OF THE LOW VOLTAGE TERMINAL BOARD AND N.C. BETWEEN TERMINALS 7 AND 6 OF THE LOW VOLTAGE TERMINAL BOARD.

Figure 3d. Typical Electrical Schematic - ComPac® II A/C, Models AVP20-60 with Electronic Control Board

1.9 ECONOMIZER COMPONENTS (COMPAC® II A/C ONLY)

Damper Actuator:

The damper actuator is a 24V motor that modulates the position of the damper blade. It is capable of driving a full 90 degrees within 90 seconds. The assembly has a spring return to close the damper during power outage.

Controls:

The economizer is controlled by the H205A enthalpy control or optional dry bulb sensor.

H205A Economizer Changeover Control:

The H205A enthalpy controller responds to the total heat content of the outdoor air to provide changeover to outside air for free cooling. The change point (factory set at "D") is adjustable from 53°F @ 50% RH (full counterclockwise) to 78°F @ 50% RH (full clockwise). Refer to Figure 4 and Figure 5.

Once the H205A has selected outside air, the mixed air sensor will limit the air temperature

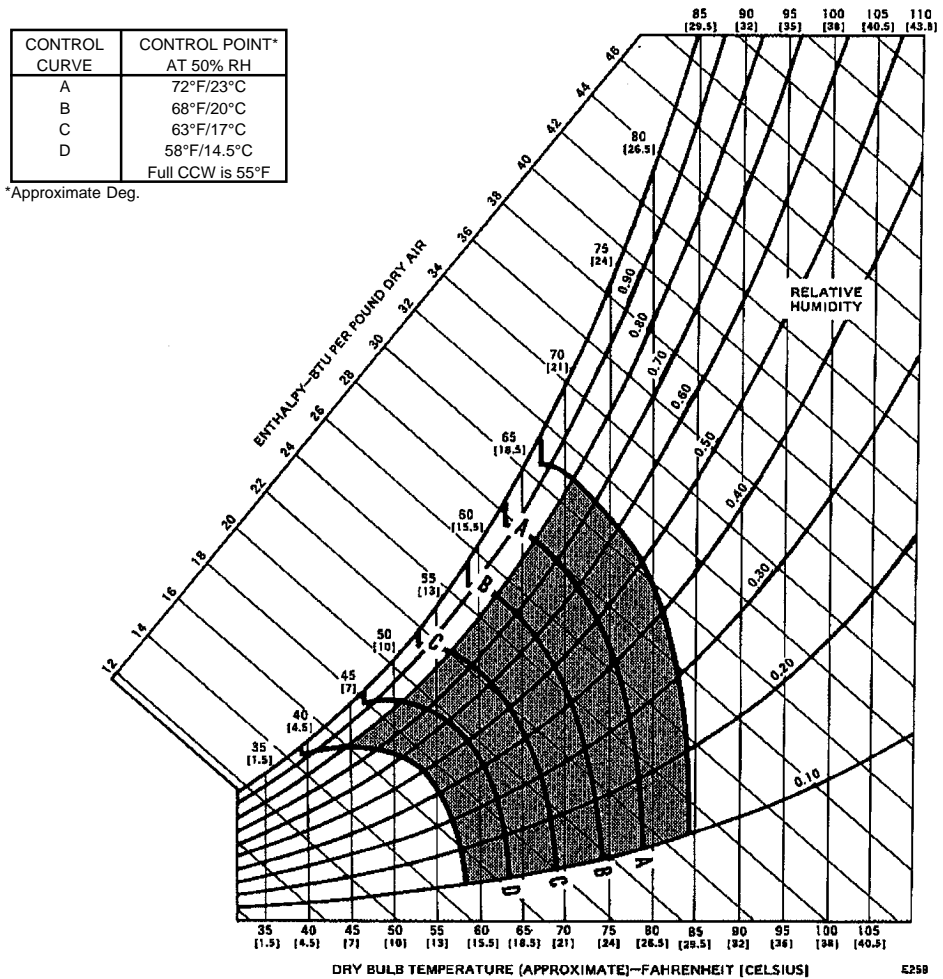

Figure 4. H205A Temperature Control Points

delivered to the space by modulating the damper blade to "mix in" a quantity of inside air to provide a constant 50° to 56°F. (Adjustable minimum potentiometer, part number 70012, is optional.)

The controller modulates the position of the outside air damper in response to input from the enthalpy and mixed air sensors. The controller is designed to maintain the supply air temperature between 50° to 56°F by mixing warm indoor air with cooler outdoor air.

On a call for cooling from the wall-mounted thermostat, if outdoor conditions are suitable, the controller will open the damper and admit outside air (i.e., economizer cooling). If the outdoor ambient is too hot or humid, the controller will place the actuator in the closed or minimum open position and activate mechanical cooling. The compressor is locked out during the economizer cooling mode.

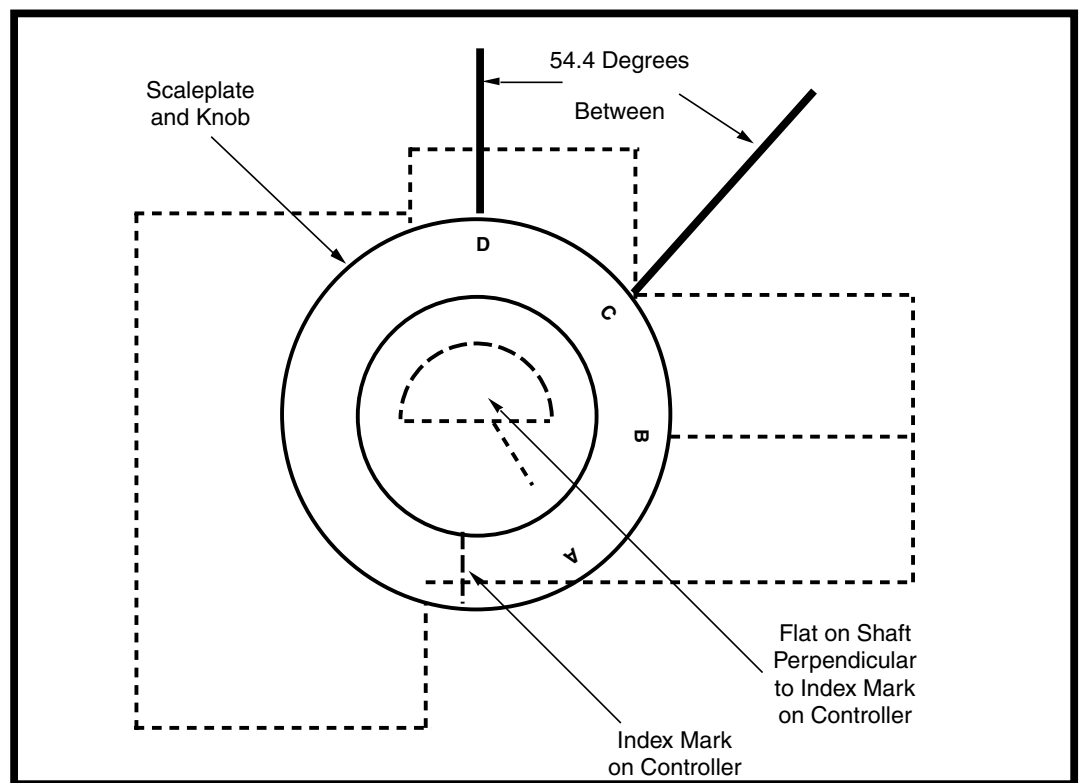

Figure 5. H205A Control Point Adjustment

Mixed Air Sensor:

The mixed air sensor is a thermistor mounted on a bracket adjacent to the right side of the blower assembly. The thermistor senses the air temperature entering the structure, and provides a signal to the economizer controller for modulating the position of the damper. Nominal resistance of the sensor at 77° F is 3000 ohms.

INSTALLATION

2.1 EQUIPMENT INSPECTION

Concealed Damage

Inspect all cartons and packages upon receipt for damage in transit. Remove cartons and check for concealed damage. **Important: keep the unit upright at all times.** Remove access panels and examine component parts. (Note: the bracket is stored in the condenser air compartment. Remove them before replacing the side screen). Inspect refrigerant circuit for fractures or breaks. The presence of refrigerant oil usually indicates a rupture. If damage is apparent, immediately file a claim with the freight carrier.

Units that have been turned on their sides or tops may have concealed damage to compressor motor mounts or to the oil system. If the unit is not upright, immediately file a claim for concealed damages and follow these steps:

1. Set unit upright and allow to stand for 24 hours with primary power turned on.
2. Attempt to start the compressor after 24 hours.
3. If the compressor will not start, makes excessive noise, or will not pump, return the unit to the freight carrier.

2.2 INSTALLATION REQUIREMENTS

General

1. Inspect unit for completeness. Check for missing parts (e.g. hardware). Refer to the installation kit information in section 2.3.
2. Remove access panels and check for loose wires. Tighten screw connections.
3. Complete and mail the warranty registration card.

You must consider all of the following when choosing the installation site:

1. **Noise.** Install the unit so that the least amount of noise will be transmitted to inhabited spaces.
2. **Condensate Drainage.** Condensate produced during operation must be discharged to a suitable drain.
3. **Placement.**
 - A) Place the unit in a shaded area, if possible.
 - B) Install it above ground for protection against flooding.
 - C) The unit exhausts air. Be sure that the airflow is not impeded by shrubbery or other obstructions.
 - D) When installing multiple units, please note the recommended clearances noted in Table 4.
4. **Airflow Requirements:**

Note the minimum CFM requirements (Table 6). Keep duct lengths as short as possible. Do not obstruct airflow through the unit.

Duct work should be designed and installed in accordance with *all* applicable safety codes and standards. Marvair® strongly recommends referring to the current edition of the National Fire Protection Association Standards 90A and 90B *before* designing and installing duct work. The duct system must be engineered to insure sufficient air flow through the unit to prevent over-heating of the heater element. This includes proper supply duct sizing, sufficient quantity of supply registers, and adequate return and filter areas. Duct work must be of correct material and must be properly insulated. Duct work

must be constructed of galvanized steel with a minimum thickness of .019 inches. Duct work must be firmly attached, secured, and sealed to prevent air leakage. See section 2.4 for additional duct work requirements.

5. **Clearances:**

Note the minimum clearances required for proper operation and service.

MODEL	MIN. CLEARANCE AROUND SIDES (SINGLE UNIT)	MIN. CLEARANCE BETWEEN UNITS (TWO UNITS)	MIN. SPACE ABOVE UNIT
20/24	30 inches	18 inches	24 inches
30/36	30 inches	18 inches	24 inches
42/48/60	30 inches	30 inches	24 inches
72	30 inches	30 inches	12 inches

Table 4. Minimum Clearances

6. **Codes:**

Make sure your installation conforms to all applicable electrical, plumbing, building, and municipal codes. Some codes may limit installation to single story structures.

7. **Electrical Supply:**

The power supply must have the appropriate voltage, phase, and ampacity for the model selected. Voltage must be maintained above minimum specified values listed below. Refer to the data sticker on the unit for ampacity requirements.

Electrical Rating Designations*	A	C	D
Nominal Voltage	208/230	208/230	460
Phase	1	3	3
Minimum Voltage	197	197	414
Maximum Voltage	253	253	506

* Letters refer to model number code designations
Refer to page 5

Table 5. Voltage Limitations

2.3 INSTALLATION MATERIALS (AVP20-72)

Installation Kits

The ComPac® I and ComPac® II A/C units, models AVP20-72, are shipped with one 12 Ga. "L" shaped bottom bracket. There is also an air intake hood packed inside of each unit. If you have not yet unpacked the unit, follow the instructions in section 2.1. All units have built-in full length mounting flanges. Therefore, use of mounting brackets is not required.

Kit Components - Models AVP20-72:

1. One 12 Ga. "L"-shaped bottom bracket

Accessories:

The package may include other factory-supplied items (optional) as follows on the next page:

P/N	Description
S/04581	CommStat 3™ Controller, Solid State Lead/Lag Controller
S/05579	LL357D2, Lead/Lag Controller with T'stat & Sub-Base; Controls 2 A/C Units

- 50123 Digital thermostat. 1 stage heat, 1 stage cool. 7 day programmable. Fan switch: Auto & On. Auto-change over. Keypad lockout. Non-volatile program memory.
- 50107 Digital thermostat. 2 stage heat, 2 stage cool. 7 day programmable. Fan switch: Auto & On. Auto-change over. Status LED's. Backlit display. Programmable fan. Non-volatile program memory.
- 80674 VPG - 20S, 20 x 8" Adjustable, Aluminum, Double Deflection Supply Grill for AVP20-24
- 80675 VPG - 30S, 28 x 8" Adjustable, Aluminum, Double Deflection Supply Grill for AVP30-36
- 80676 VPG - 40S, 30 x 10" Adjustable, Aluminum, Double Deflection Supply Grill for AVP42-48-60-72
- 80677 VPG - 20R, 20 x 12" Aluminum Return Grill for AVP20-24
- 80678 VPG - 30R, 28 x 14" Aluminum Return Grill for AVP30-36
- 80679 VPG - 40R, 30 x 16" Aluminum Return Grill for AVP42-48-60-72
- 06777 Start Relay and Capacitor for AVP20-36 (Field Installed) (Not recommended for scroll compressors.)

Additional Items Needed:

Additional hardware and miscellaneous supplies (not furnished by Marvair®) are needed for installation. For example, the list below contains approximate quantities of items typically needed for mounting a unit on a wood frame wall structure. Concrete or fiberglass structures have different requirements.

ComPac® I and ComPac® II A/C Models 20-72

- (10) **3/8" carriage head mounting bolts** for unit mounting flanges. The length needed is typically the wall thickness plus one inch.
- (20) **3/8" washers**
- (10) **3/8" hex nuts**
- (6) **3/8" x 2-1/2" lag screws** for bottom bracket
 - **Silicone Sealer** to seal around cracks and openings
 - **4-conductor low voltage multicolored wire cable** (i.e. thermostat wire)
 - **Appropriate electrical supplies** such as **conduit, electrical boxes, fittings, wire connectors**, etc.
 - **High voltage wire**, sized to handle the MCA (minimum circuit ampacity) listed on the data plate.
 - **Over-Current Protection Device** sized in accordance with the MFS (maximum fuse size) listed on the unit data plate.

2.4 PORTING AND DUCT WORK (AVP20-72)



General Information

Note: The following instructions are for general guidance only. Due to the wide variety of installation possibilities, specific instructions will not be given. When in doubt, follow standard and accepted installation practices, or contact Marvair® for additional assistance.

Wall Openings

Measure the dimensions of the supply and return ports on the unit.

Cut the openings in the exterior wall for the supply and return. **IMPORTANT: All units with electric heat must have one inch clearance on all four sides of the supply outlet duct flange on the unit. The one inch clearance must extend on all sides of the supply duct for the first three feet from the unit.**

IMPORTANT: Marvair® requires a minimum of one inch from the surface of any supply ducts to combustible material for the first three feet of the duct.

Ducting

Extensions should be cut flush with the inside wall for applications without duct work.

Applications using duct work should be designed and installed in accordance with *all* applicable safety codes and standards. Marvair® strongly recommends referring to the current edition of the National Fire Protection Association Standards 90A and 90B *before* designing and installing duct work. The duct system must be engineered to insure sufficient air flow through the unit to prevent over-heating of the heater element. This includes proper supply duct sizing, sufficient quantity of supply registers, adequate return and filter area. Ductwork must be of correct material and must be properly insulated. Duct work must be constructed of galvanized steel with a minimum thickness of .019 inches. Ductwork must be firmly attached, secured and sealed to prevent air leakage. Do not use duct liner on inside of supply duct within 4 feet of the unit.

Galvanized metal duct extensions should be used to simplify connections to duct work and grilles. Use fabric boots to prevent the transmission of vibration through the duct system. The fabric must be U.L. rated to a minimum of 197°F.

Minimum Airflow Requirements

The duct system must be engineered to assure sufficient air flow through the unit even under adverse conditions such as dirty filters, etc. Use **Table 6** below and **Table 1, CFM at External Static Pressure (Wet Coil)** in section 1.4.

BASIC MODEL	MAXIMUM TOTAL STATIC	MINIMUM FILTER AREA
20/24	.30	2.25 sq. ft.
30/36	.40	3.00 sq. ft.
42/48/60/72	.50	3.90 sq. ft.

Table 6. Maximum Static Pressure

(For units with 2" Pleated Filters)

2.5 FRESH AIR HOOD INSTALLATION (AVP20-72)

1. Cut and remove insulation on the inside of the lower front access panel in the shape of the rectangular opening. See Figure 6.
2. Insert flange on hood into opening and secure using the two #8 x 1/2 sheet metal screws supplied.

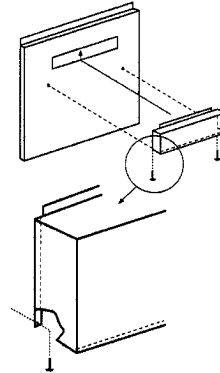

Figure 6. Fresh Air Hood Installation

2.6 BRACKET INSTALLATION (AVP20-72)

1. Models AVP20-72 have built-in mounting flanges.
2. Apply a bead of silicone sealer on the wall side of the bottom support brackets on the unit. Circle the mounting holes with the silicone bead.
3. Refer to Figure 7. Attach the bottom support bracket to the wall using appropriate 3/8" diameter hardware.

For example, on wooden structures, use 3/8" x 2-1/2" all-thread lag screws. The screws must penetrate the center of the wall stud. Drill a pilot hole in the stud to prevent it from splitting.

2.7 MOUNTING THE UNIT (AVP20-72)

1. For wiring into the back of unit, locate the lower of the two knockouts on the wall side of the unit. Drill a one inch hole in the shelter wall to match this opening. Allow sufficient clearance to run 3/4" conduit through the hole and to the unit.
2. Using an appropriate and safe lifting device, set the unit on the bottom support bracket mounted on the wall. You must stabilize the unit on the bracket with the lifting device or by some other means - the bracket alone is not sufficient.
3. Make sure that the duct flanges are properly aligned with the wall opening. Adjust as necessary.
4. Note the holes in each side flange. Using the holes for guides, drill holes through the wall with a 3/8" drill bit. Insert the 3/8" x 5" bolts through the flanges. Install nuts and washers on the inside of the shelter. Tighten the bolts to secure the unit.
5. Apply a bead of silicone where the mounting flange contacts the unit and the shelter wall.
6. On the inside of the shelter, install the wall sleeves in the supply and return air openings. The sleeves may be trimmed to fit flush with the inside wall.
7. Check the fit of each sleeve to its mating flange for possible air leaks. Apply silicone sealer to close any gaps. Install the air return and supply grilles.

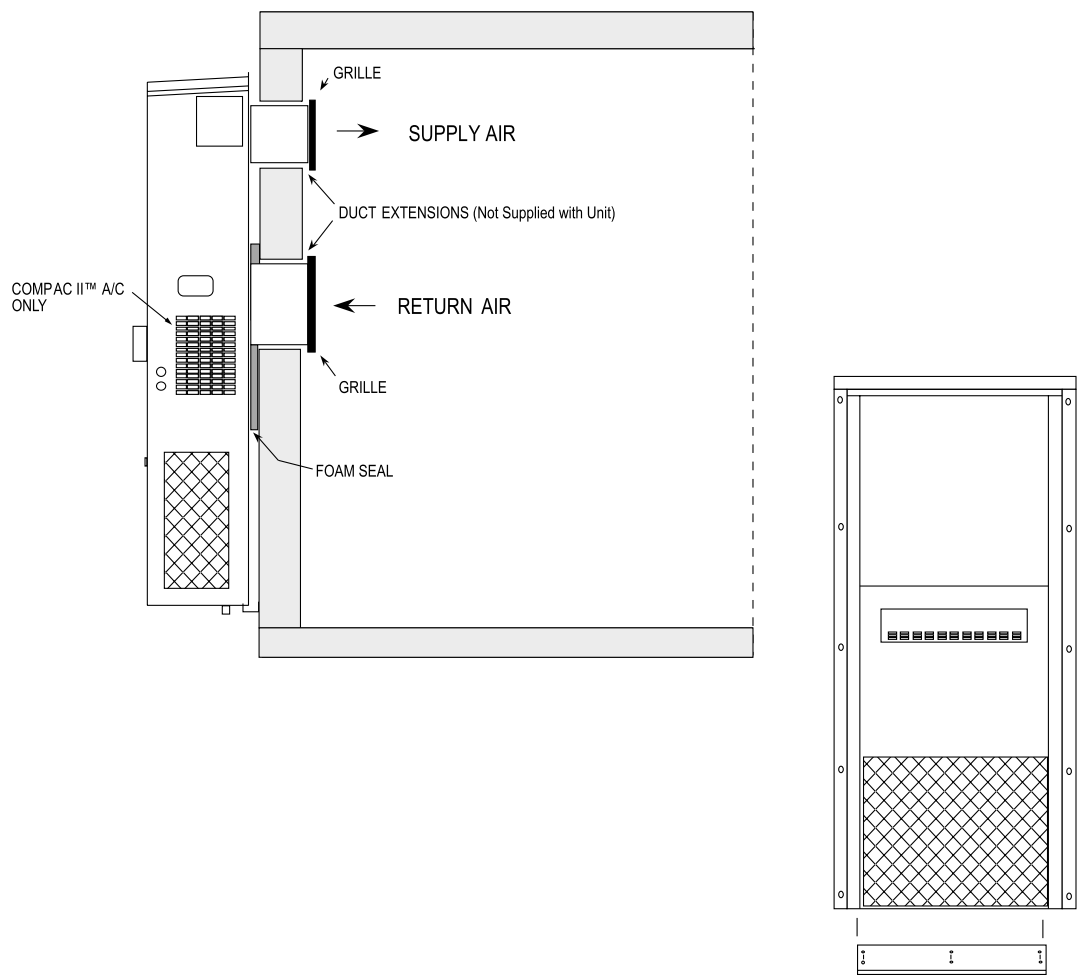

Figure 7. ComPac® I and ComPac® II A/C Wall Mount Detail (AVP20-72)

2.8 ELECTRICAL CONNECTIONS



Important

All electrical work must meet the requirements of local codes and ordinances. Work should be done **only by qualified persons.**

The ComPac® units may incorporate an internal crankcase heater for compressor protection. **The crankcase heater must be energized for at least 24 hours prior to starting the compressor.**

High Voltage Wiring - (Single Units)

The power supply should have the proper voltage, phase, and ampacity for the selected model.

1. Size the incoming power supply lines according to Code requirements. Run the power conductors through the knockouts on the wall side of the unit, or to those adjacent to the electrical control box. Use appropriate conduit and strain reliefs.
2. Connect the wires to the input side of the internal breaker or terminal block (L1 & L2 for single-phase units; L1, L2, & L3 for three-phase models).
3. Install the ground wire on the ground lug.

Dual Unit Phasing

For applications where one controller operates two units, e.g., the CommStat 3 or LL357D. The current model, LL357D2, does not require unit phasing. However, if other devices are connected to the control system, phasing of the air conditioner is required. Earlier models; i.e., LL357, LL357A, require the unit to be properly phased.

1. Wire each unit as described in steps 1 through 3 above.
2. Test for proper phasing as follows:
 - A. Power up the units.
 - B. Using an AC volt meter set to the 300 volt scale, measure voltage between terminal L1 on the compressor contactor of unit #1 and terminal L1 on the compressor contactor of unit #2. If voltage is present, units are wired out of phase and must be rewired.
 - C. If units are not in phase, turn off power and reverse the field power leads connected to the internal circuit breaker on one of the units only.
 - D. Restore power and retest the phase (step B). When the voltage reads "0", the units are in phase.
 - E. Turn off power and proceed.

CommStat 3™ Controller (See Figure 8c)

The CommStat 3™ Controller by Marvair® is a solid state control package designed to operate a fully or partially redundant air conditioning system for a telecommunication cabinet or shelter. The CommStat 3 Controller is factory programmed with standard industry set points to facilitate installation. If desired, each of the set points can be quickly and easily changed in the field by the installer. It can be used with Marvair's ComPac® I or II unique vertical packaged wall mount air conditioners or Marvair's environmental control units. See Commstat 3 Product Data Sheet for installation and programming instructions.

LL357D2 Lead/Lag Controller (See Figure 8b)

The Marvair® LL357D2 is a complete control package designed to operate a fully or partially redundant air conditioning system. It consists of a two-stage heat and two-stage cool electronic thermostat and a solid state timer. It can be used with either the Marvair ComPac® I vertical packaged wall mount air conditioner or our unique ComPac® II air conditioner with built-in economizer. The LL357D2 provides environmental control and the security demanded by the communication shelter industry for a backup unit. The lead/lag controller insures equal wear on both air conditioners while allowing the lag unit to assist upon demand. The LL357D2 is factory wired, tested, and mounted in an enclosure for quick installation. Refer to the LL357D2 Product Data Sheet for complete installation instructions.

Thermostat/Sub-Base

- Thermostat Range: 40°F(4°C) to 98°F (37°C)
- Changeover differential: Adjustable, 3°F to 10°F (1.5°C to 5.6°C) between heating and cooling. May be set apart for greater separation.
- Inter-stage differential:
Differential is factory set at 2° (1.1°C) between heating or cooling stages (make and break points).
Operating differential is approximately 1.9°F (1.1°C) between stages in heating and cooling.
- 24 Volt Control

- Automatic system switch, No fan signal.
- Automatic switch-over between heating and cooling.
- Digital display in °F or °C.
- Setpoints are permanently held in memory - no batteries required.

Timing Device

- Solid state timer with both 3.5 and 7 day changeover capability.
NOTE: Cut timer circuit wire to provide 3.5 day changeover. Timing accuracy $\pm 5\%$.
- Momentary push button for accelerated manual timer advance. (9 seconds = 7 days)
- Light emitting diode indicates power on and identifies the lead unit.
- Timing logic retention for up to one hour on power loss.

Low Voltage Wiring

1. On single units, pull the low voltage wiring (e.g., 18 gauge 4-conductor Class 2 thermostat wire) from the ComPac® A/C into the thermostat / subbase assembly.
2. Mount the subbase on a level plane. Use a spirit level. Connect the thermostat wire to the ComPac® unit terminal block and the thermostat as shown in Figure 8a.
3. On dual units, refer to the Marvair® LL357D2 *Lead/Lag Controller Specification Sheet*. Level and install the LL357D2 subbase. Wire the two ComPac® units to the Lead/Lag Controller, according to the wiring diagram on the specification sheet and as shown in Figure 8b (note: the diagram also appears on the back cover of the LL357D2).

Remote Signalling: Terminals 5 & 7 on the ComPac® A/C terminal board are dry contacts which can be used for remote signalling in the event of a/c cutoff on low or high pressure limit.

Continuous fan operation: For continuous indoor fan operation on single units, install a jumper between terminals 8 and 3. For continuous indoor fan operation on dual units using the LL357D2, install jumper between 8 and 3 and remove jumper between 1 and 3.

208/230v Power Supply: For units designed for operation on 208/230v, 60Hz power supply, the transformer is factory wired for a 230v power supply. For a 208v power supply, remove the orange lead from the transformer and connect the red lead. Insulate the orange lead.

Unit Shutdown/Fire Alarm Systems

Immediate shutdown of the air conditioning system can be accomplished by wiring the normally closed set of contacts in the fire extinguishing or alarm system across terminals 8 and 10 on the low voltage terminal board inside the air conditioner. Note: The factory jumper between these terminals must be removed.

This function cannot be accomplished at the wall thermostat because the blower timed delay relay connections inside the unit allow the indoor blower to operate for 90 seconds following each cool "on" cycle.

NOTE: The Blower Timed Delay Relay (BTR) allows the indoor fan to run for approximately 90 seconds after the compressor is off. This operation provides a small improvement in system S.E.E.R.

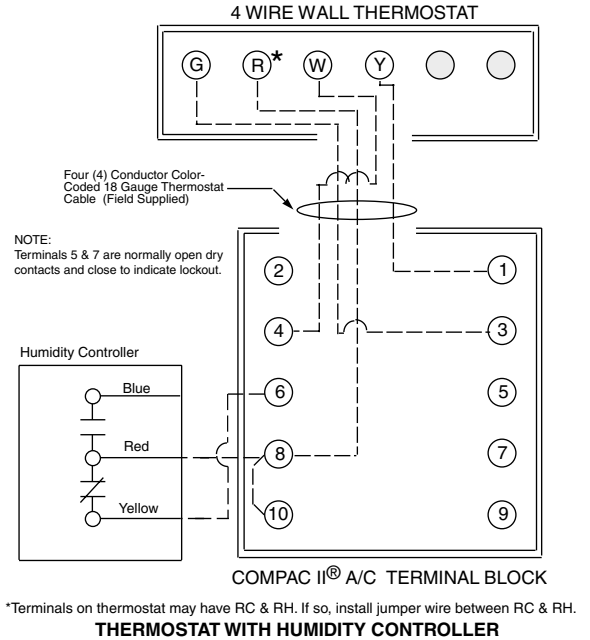
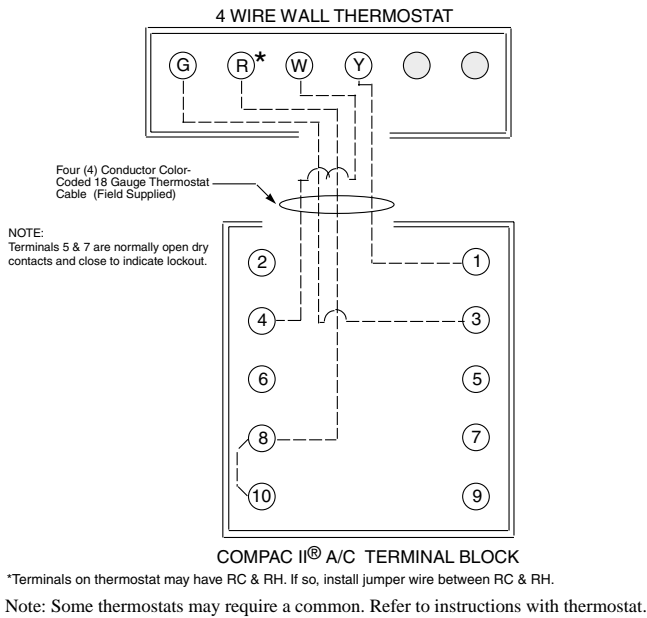

Figure 8a. Thermostat Wiring Details

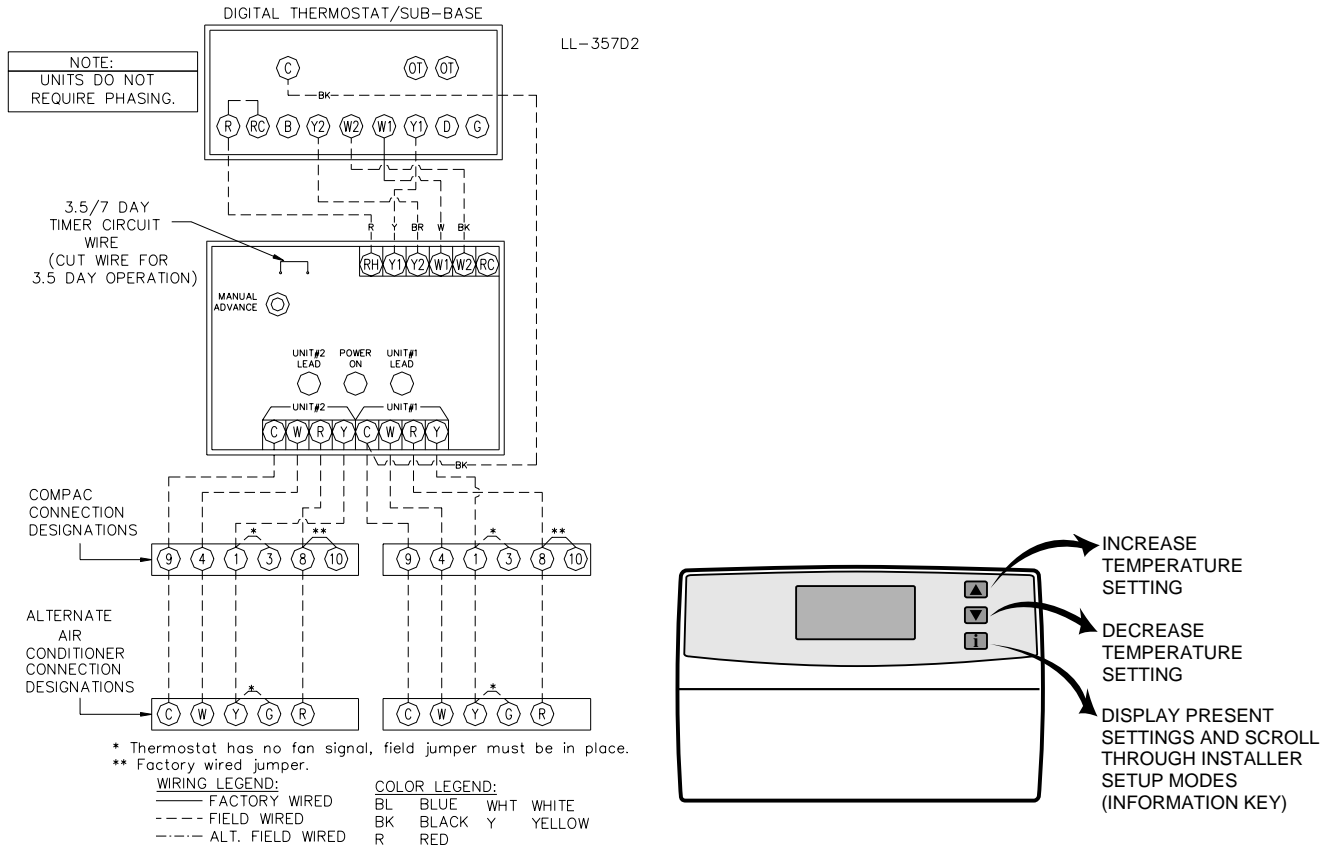

Figure 8b. LL357D2 Wiring Diagram & Thermostat Keys

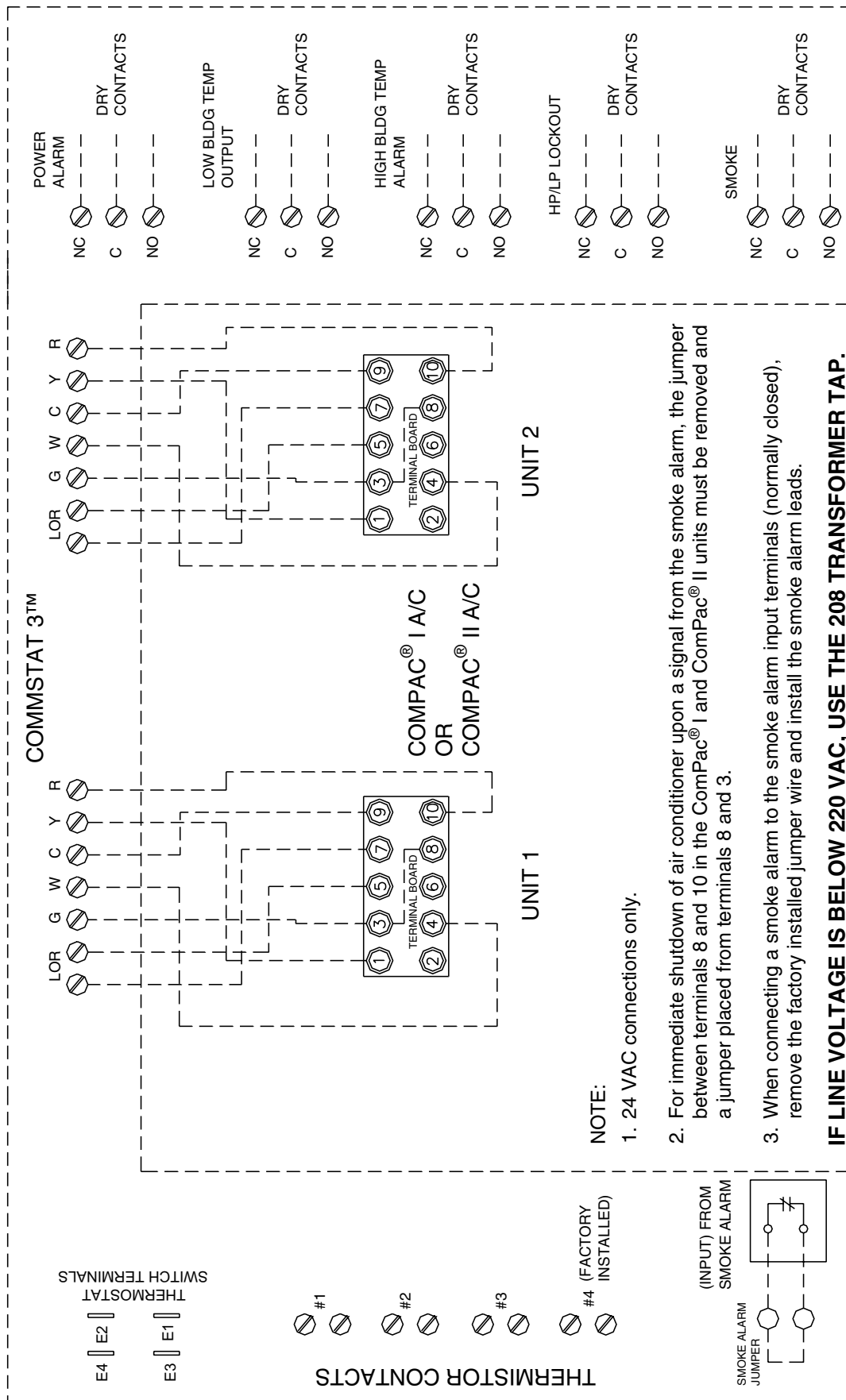

Figure 8c. CommStat 3™ Wiring Diagram

START-UP

3.1 CHECK-OUT OF COOLING CYCLE

Important: Be sure that the crankcase heater (if used) has been energized for at least 24 hours before starting the unit(s). Double-check all electrical connections before applying power.

Procedure:

1. Set the cooling temperature on the wall thermostat to a point *higher* than the ambient temperature. Set the heating temperature to a temperature that is *lower* than the ambient.
2. Set the thermostat system switch in the AUTO position. Nothing should operate at this time.
3. Set the time delay in the ComPac® I or ComPac® II A/C control box to three minutes. Check the changeover setting of the H205A or dry bulb sensor and reset it if needed (ComPac II A/C only). See Section 1.6.
4. Slowly lower the thermostat's cooling temperature until the switch closes. The indoor fan should operate.

Once the indoor fan turns on, allow approximately three minutes for the compressor to start. Note that the outdoor fan may not come on immediately, because it is cycled by refrigerant pressures.

NOTE: (ComPac® II A/C only) To check the system operation under different ambient conditions, the air temperature and enthalpy sensors must be "tricked". When outdoor ambient conditions are higher than the control setting, a component cooler aerosol may be sprayed directly into the enthalpy sensor to simulate low enthalpy conditions, causing the economizer damper to open.

Alternately, when outdoor conditions are lower than the set point, a source of heat such as a hair dryer can be directed on the air temperature sensor to simulate warmer conditions, which will bring on mechanical cooling and start the compressor.

5. To stop cooling, slowly raise the thermostat cooling to a temperature higher than the ambient.

If the unit fails to operate, refer to the troubleshooting information in Chapter 4.

Follow the same procedure for additional units.

NOTE: Blower Time Delay Relay (BTR) allows the indoor fan to run for approximately 90 seconds after the compressor is off. This operation provides a small improvement in system S.E.E.R.

3.2 CHECK-OUT OF HEATING CYCLE

Procedure: (Applies only to units with resistance elements)

1. Raise the heating temperature to a setting which is higher than the ambient temperature. The fan and electric heat should immediately cycle on.
2. Move the system switch to the "OFF" position. All functions should stop.

NOTE: (ComPac® II A/C only) The damper blade should remain closed during the heating cycle (unless the minimum position potentiometer has been set for constant ventilation). A fully counterclockwise position corresponds to full closure of the damper.

3.3 A/C TESTING WITH LL357D2

Note: The LL357D2 does not require the units to be in phase.

Procedure: (A/C Testing with LL357D2 Lead/Lag Control for Two Units)

1. Set the cooling temperature on the wall thermostat to a point higher than the ambient temperature. Set the heating temperature to a temperature that is lower than the ambient temperature. Turn the selector switch to the “off” position.
2. Set the time delay on unit No. 1 to “3” minutes, and No. 2 to “5” minutes.
3. Set the change over setting of the enthalpy control to the “d” setting (ComPac® II A/C only).
4. Provide power to A/C units and turn disconnects on.
5. Check incoming power to each unit. For units designed for operation on 208/230v, 60hz power supply, the transformer is factory wired for a 230 power supply. For a 208 power supply remove the orange lead from the transformer and connect the red lead. Insulate the orange lead.
6. Cooling. Turn the selector switch on the thermostat to the “auto” position. Slowly lower the cooling temperature until the switch closes. The indoor fan should operate on the lead unit. Once the indoor fan turns on, allow approximately 3 to 5 minutes for the compressor to start. Note that the outdoor fan may not come on immediately because it is cycled by refrigerant pressures. Next, lower the temperature until the switch closes. Follow the above procedures for the lag unit.

The green light on the lead lag control should be on. One amber light will be on to identify the lead unit. The other light should be off. If the lag unit comes on with the lead unit the light for the lag unit will not come on. You should never have all 3 lights on at one time.

Allow the units to run for 2 to 3 minutes then check the temperature differential between the return air and the supply air with digital thermometer. The temperature differential should be between 12 and 20 degrees depending on ambient temperature.

Next, slowly raise the cooling temperature until the switch opens. The compressor and outdoor fan should turn off. The indoor fan will continue to run for “90” seconds until the blower time delay relay (BTR) times out. Raise the temperature until the switch opens. The lead unit will shut down accordingly to the same procedures as outlines above.

Note: (ComPac® II A/C only) To check the system operation under different ambient conditions, the air temperature and enthalpy sensors must be “tricked”. When outdoor ambient conditions are higher than the control setting, a component cooler aerosol may be sprayed directly into the enthalpy sensor to stimulate low enthalpy conditions, causing the economizer damper to open.

Alternately, when outdoor conditions are lower than the set point, a source of heat such as a hair dryer can be directed on the enthalpy sensor to simulate warm conditions, which will bring on mechanical cooling and start the compressor.

7. Heating. Slowly raise the heating temperature until the switch closes. The fan and electrical heat should immediately cycle on. The unit should start blowing warm air in 2 to 3 minutes. Next, raise the temperature until the switch closes. Follow the above procedures for lag unit.

Hold the manual advance button in for nine seconds the lead lag lights should switch. Next, slowly lower the temperature until the switches open. The lag unit should shut down immediately. Next, slowly lower the temperature until the switch opens, the lead unit should shut down immediately.

8. Replace thermostat cover and panels on the unit.

TROUBLESHOOTING

4.1 OVERVIEW

A comprehensive understanding of the operation of the ComPac® A/C is a prerequisite to troubleshooting. Please read the Chapter 1 for basic information about the unit.

Marvair's ComPac® air conditioners are thoroughly tested before they are shipped from the factory. Of course, it is possible that a defect may escape undetected, or damage may have occurred during transportation. However, the great majority of problems result from installation errors.

If you experience difficulties with the ComPac® A/C, please review the installation steps in Chapter 2.

Much time can be saved by taking a thoughtful and orderly approach to troubleshooting. Start with a visual check - are there loose wires, crimped tubing, missing parts, etc? Begin deeper analysis only after making this initial inspection.

The troubleshooting information in this manual is basic. The troubleshooting section contains problem/solution charts for general problems, followed by a compressor section.

Not every problem can be anticipated. If you discover a problem that is not covered in this manual, we would be very grateful if you would bring it to the attention of our service department for incorporation in future revisions.

As always, please exercise caution and good judgement when servicing the ComPac® A/C. Use only safe and proven service techniques. Use refrigeration goggles when servicing the refrigeration circuit.



The refrigerant circuit has hot surfaces, and the electrical voltages inside of the unit may be hazardous or lethal. **SERVICE MAY BE PERFORMED ONLY BY QUALIFIED AND EXPERIENCED PERSONS.**

4.2 FAILURE SYMPTOMS GUIDE

PROBLEM / SYMPTOM	LIKELY CAUSE(S)	CORRECTION
<p>A. Unit does not run.</p> <p>NOTE: An internal anti-short-cycle timer will prevent the unit from starting for .2 to 8 minutes following start-up.</p>	<ol style="list-style-type: none"> 1. Power supply problem. 2. Tripped internal disconnect. 3. Shut off by external thermostat or thermostat is defective. 4. Unit off on high or low pressure limit. 5. Internal component or connection failure. 	<ol style="list-style-type: none"> 1. Check power supply for adequate phase and voltage. Check wiring to unit and external breakers or fuses. 2. Check internal circuit protection devices for continuity. 3. Check operation of wall-mounted thermostat. 4. Reset pressure switch. 5. Check for loose wiring. Check components for failure.
<p>B. Unit runs for long periods or continuously; cooling is insufficient.</p>	<ol style="list-style-type: none"> 1. Dirty filter or reduced airflow 2. Low refrigerant. 3. Component failure. 4. Unit undersized for job. 	<ol style="list-style-type: none"> 1. Check air filter(s). Check blower operation. Remove airflow restriction. 2. Check for proper charge and possible refrigerant leak. 3. Check internal components, especially compressor for proper operation. 4. Add additional units for greater capacity.
<p>C. Unit cycles on high/low pressure limit.</p>	<ol style="list-style-type: none"> 1. Loss or restriction of airflow. 2. Restriction in refrigerant circuit. 3. Refrigerant overcharge (following field service) 4. Defective pressure control. 	<ol style="list-style-type: none"> 1. Check blower assembly for proper operation. Look for airflow restrictions, e.g., the air filter. Check blower motor and condenser fan. 2. Check for blockage or restriction, especially filter drier and capillary tube assembly. 3. Evacuate and recharge to factory specifications. 4. Check limit cutout pressures. Control is set to actuate at approximately 35 PSIG (low pressure) and 400 PSIG (high pressure).
<p>D. Unit blows fuses or trips circuit breaker.</p>	<ol style="list-style-type: none"> 1. Inadequate circuit ampacity. 2. Short, loose, or improper connection in field wiring. 3. Internal short circuit. Loose or improper connection(s) in unit. 4. Excessively high or low supply voltage or phase loss (3ϕ only). 	<ol style="list-style-type: none"> 1. Note electrical requirements in Chapter 2 and correct as necessary. 2. Check field wiring for errors. 3. Check wiring in unit. See wiring and schematic diagrams. Test components (especially the compressor) for shorts. 4. Note voltage range limitations specific to the compressor troubleshooting section.

PROBLEM/SYMPTOM	LIKELY CAUSE(S)	CORRECTION
E. Water on floor near unit.	1. Obstruction in condensate line. 2. Obstruction or leak in condensate pan. 3. Unit is not level.	1. Check for clog or restriction. 2. Check pan for leak or blockage. 3. Level unit.
F. No space heating or reduced heating (units equipped with resistance elements)	1. Defective heating element(s). 2. Thermal limit open. 3. Defective heater relay. 4. Open thermal cut-out (TCO).	1. Check resistance element(s) for continuity. 2. Check continuity across thermal limit switch. 3. Check relay for proper operation. Replace if defective. 4. Check across TCO (adjacent to element(s)) for continuity. It is normally closed.

4.3 COMPRESSOR TROUBLESHOOTING

NOTE: It is important to rule out other component failures before condemning the compressor.

The following electrical tests will aid diagnosis:

- Start-Up Voltage:** Measure the voltage at the compressor terminals during start-up. The voltage must exceed the minimum shown in Table 5, section 2.2, or compressor failure is likely. A low voltage condition must be corrected.
- Running Amperage:** Connect a clip-on type ammeter to the (common) lead to the compressor. Turn on the supply voltage and energize the unit. The compressor will initially draw high amperage; it should soon drop to the RLA value or less. If the amperage stays high, check the motor winding resistances.

NOTE: Feel the top of the compressor to see if it has overheated. If it is hot, the internal overload may be open. You may have to wait several hours for it to reset.

- Motor Winding Resistances:** Using a digital volt-ohm meter (VOM), measure the resistance across the compressor windings as shown below.

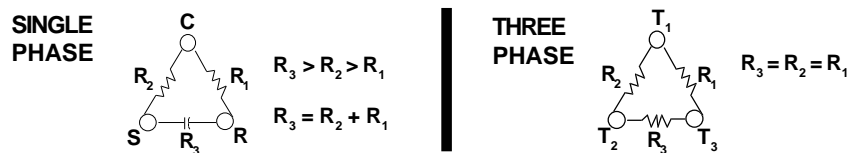

Resistance can be measured as shown above. Any deviation from above values could indicate a defective compressor.

- High Voltage/Insulation Test:** Test internal leakage with a megohmmeter. Attach one lead to the compressor case on a bare metal tube and to each compressor terminal to test the motor windings. A short circuit at high voltages indicates a motor defect. Do not do this test under vacuum.
- On single phase models, check the capacitor by substitution.

4.4 CONTROL BOARD DIAGNOSIS

The control board (see section 1.6a for a complete description of the control board) has a red diagnostic LED which indicates the lockout fault. The control board will enter into and indicate lockout if either of the fault conditions (LPS or HPS) occur twice.

The contactor must be closed before the first fault condition can be recognized by the control board. The contactor will be closed 3 minutes after the unit is energized and only if cooling is required. The first fault condition will open the contactor and shutdown the unit. The contactor on the unit that has the fault condition must be closed before the second fault condition can be recognized by the control board. The contactor on the unit with the fault condition will close after 3 minutes if the unit is still calling for cooling and if the fault condition no longer exists. If you get a second fault condition, the contactor will open and shutdown the unit. The “red” led will have one blink if the high pressure switch has opened twice and will have two blinks if the low pressure switch has opened twice. The unit must be in the cooling mode (compressor contactor Closed) before a fault condition can occur.

PARTS LIST

5.1 PARTS LIST

Item	Description	ComPac® I and II (AVPxxAC)							
		20	24	30	36	42	48	60	72
1	Compressor (Comp)								
	ACA (1 Ph, 230 V)	10046	10205	10208	10233	10052	10202	10108	P/10005
	ACA (1 Ph, 230 V, Optional Scroll)	n/a	10104	10109	10079	n/a	n/a	n/a	n/a
	ACC (3 Ph, 230 V)	n/a	10206	10209	10226	10093	10203	10140	10178
	ACC (3 Ph, 230 V, Optional Scroll)	n/a	10116	10118	10092	n/a	n/a	n/a	n/a
	ACD (3 Ph, 460 V)	n/a	10207	10211	10227	10094	10204	10120	10179
2	ACA (3 Ph, 460 V, Optional Scroll)	n/a	10114	10117	10091	n/a	n/a	n/a	n/a
	Compressor Capacitor, ACA	50265	50265	50280	50315	50322	50294	50159	50159
3	Compressor Capacitor, ACA, (Scroll)	n/a	50280	50321	50310	n/a	n/a	n/a	n/a
	Compressor Contactor (CC)								
4	ACA (1 Phase)	50010	50010	50010	50020	50020	50020	50030	50030
	ACC, ACD (3 Phase)	n/a	50040	50040	50040	50040	50040	50040	50040
5	Condenser Coil	60208	60208	60375	60375	60350	60345	60345	60007 (2)
6	Outdoor Fan Motor (OFM) Standard	40031	40031	40096	40096	40098	40098	40098	40051
	Outdoor Fan Motor (OFM) Extreme Duty	40054	40054	40054	40054	40051	40051	40051	40051
7	Outdoor Motor Capacitor (OFMC)	50350	50350	50350	50350	50240	50240	50240	50360
8	Fan Blade	30110	30110	30115	30115	30135	30135	30135	30149
9	Evaporator Coil	60207	60207	60385	60385	60360	60340	60061	60027
10	Indoor Motor (IBM)	40045	40045	40055	40055	40099	40099	40046	40046
11	Indoor Motor Capacitor (IMC)	50350	50350	50350	50350	50360	50360	50360	50360
12	Indoor Blower - Left Hand	30060	30060	30050	30050	30090	30090	30012	30025
13a	Indoor Blower - Right Hand	30065	30065	30055	30055	30092	30092	30013	30024
	Capillary Tube	80868	80869	80865	80866	80903	80660	n/a	n/a
13b	Quantity Needed	3	3	2	2	2	4	n/a	n/a
13c	Distributor - Indoor (for Cap Tubes)	80042	20294	20295	20295	80042	80042	n/a	n/a
13d	Orifice - Cooling	n/a	n/a	n/a	n/a	n/a	n/a	(.088)	(.094)
13d	Distributor - Indoor (Chatleff)	n/a	n/a	n/a	n/a	n/a	n/a	20033	20239
14	Heating Element (EH)	SEE HEATING ELEMENT AND RELAY CHART BELOW							
15	Dual Limit Control	SEE HEATING ELEMENT AND RELAY CHART BELOW							
16	Limit Control, Automatic Reset	70005	70005	70005	70005	70005	70005	70005	70005
17	Heater Contactor/Relay	SEE HEATING ELEMENT AND RELAY CHART BELOW							
18	Fuse Link (FL)	n/a	n/a	n/a	n/a	n/a	n/a	n/a	n/a
19	Control Transformer, 40 va (Tran)	50141	50141	50141	50141	50141	50141	50141	50141
20	Transformer (ACD Only)	n/a	50146	50146	50146	50147	50147	P/50007	P/50008
21	Blower Time Delay Relay (BTR)	50419	50419	50419	50419	50419	50419	50419	50419
22	Lockout Relay (LOR)	50214	50214	50214	50214	50214	50214	50214	50214
23	Clip for Low Vibration	01257	01257	01257	01257	01257	01257	01257	01257
24	Adjustable Time Delay Relay (TD)	70063	70063	70063	70063	70063	70063	70063	70063
25	Timed Low Pressure By-pass (TLPBP)	70071	70071	70071	70071	70071	70071	70071	70071
26	Control Board (Alt. for Items 21 - 25)	70281	70281	70281	70281	70281	70281	70281	70281
27	Terminal Board (TB)	80786	80786	80786	80786	80786	80786	80786	80786
28	Disconnect	SEE DISCONNECTS CHART BELOW							
29	Terminal Block	n/a	n/a	n/a	n/a	n/a	n/a	n/a	n/a
30	High Pressure Switch (HPS)	70080	70080	70080	70080	70080	70080	70279	70080
31	Low Pressure Switch (LPS)	70050	70050	70050	70050	70050	70050	70050	70050
32	Motor Mounting Bracket, OFM	80420	80420	80420	80420	80426	80426	80426	n/a
33	Motor Mounting Bracket, IBM	80427	80427	80427	80427	80428	80428	80428	80428
34	Economizer Package Actuator (EPA)	40101	40101	40101	40101	40101	40101	40101	40101
35	Terminal Lug	80271	80271	80271	80271	80271	80271	80271	80271
36	H205A Enthalpy Control (EC)	70230	70230	70230	70230	70230	70230	70230	70230
37	Mixed Air Relay (MAR)	50164	50164	50164	50164	50164	50164	50164	50164
38	Mixed Air Sensor (MAS)	70229	70229	70229	70229	70229	70229	70229	70229
39	Heat Blower Relay	SEE HEATING ELEMENT AND RELAY CHART BELOW							
40	Outdoor Fan Relay	SEE HEATING ELEMENT AND RELAY CHART BELOW							
41	Filter Drier	70370	70370	70370	70370	70370	70370	70389	70425
42	2" Pleated Filter	80137	80137	80138	80138	80162	80162	80162	81257 (2)
43	Low Ambient Fan Cycle Control*	S/03998	S/03998	S/03998	S/03998	S/03998	S/03998	S/03998	S/03998
44	Fan Cycle Control Relay	n/a	n/a	n/a	n/a	P/50182	P/50182	P/50182	P/50182

*S/03998 is the field replacement for the factory installed fan cycle control (20175). Includes swivel tee.

*1 = Location May Vary 2 = 460V, 3ø Only 3 = ComPac® I A/C Only
 4 = ComPac® II A/C Only 5 = Optional

Unit	kW	Volts	Heat Element		Dual Limit Control		Relays		Heater	
			Part Number	Qty	Part Number	Qty	Fan	Heat/Blower	Contactor	Relay
0	240	n/a	n/a	n/a	n/a	n/a	n/a	n/a	n/a	n/a
2.2	240	70397	n/a	n/a	n/a	n/a	n/a	n/a	n/a	50205
3.6	240	70136	n/a	n/a	n/a	n/a	n/a	n/a	50020	n/a
4	240	70413	1	70006	n/a	n/a	n/a	n/a	50020	n/a
5	240	70412	1	70006	n/a	n/a	n/a	n/a	50020	n/a
6	240	70444	3	70006	n/a	n/a	n/a	n/a	50040	n/a
8	240	70414	2	70006	n/a	n/a	n/a	n/a	50030	n/a
9	240	70445	3	70006	n/a	n/a	n/a	n/a	50040	n/a
10	240	70411	2	70006	n/a	n/a	n/a	n/a	50030	n/a
12	240	70446	3	70006	n/a	n/a	n/a	n/a	50040	n/a
15	240	70410	3	70006	n/a	n/a	n/a	n/a	50040	n/a
0	460	n/a	n/a	n/a	n/a	50190	n/a	n/a	n/a	n/a
6	460	70440	3	70006	50190	50190	50040	n/a	n/a	n/a
9	460	70441	3	70006	50190	50190	50040	n/a	n/a	n/a
12	460	70442	3	70006	50190	50190	50040	n/a	n/a	n/a
15	460	70443	3	70006	50190	50190	50040	n/a	n/a	n/a

Part Number	Volts	Phase
70178	240	1
70183	240	3
70299	460	3

5.2 ILLUSTRATIONS

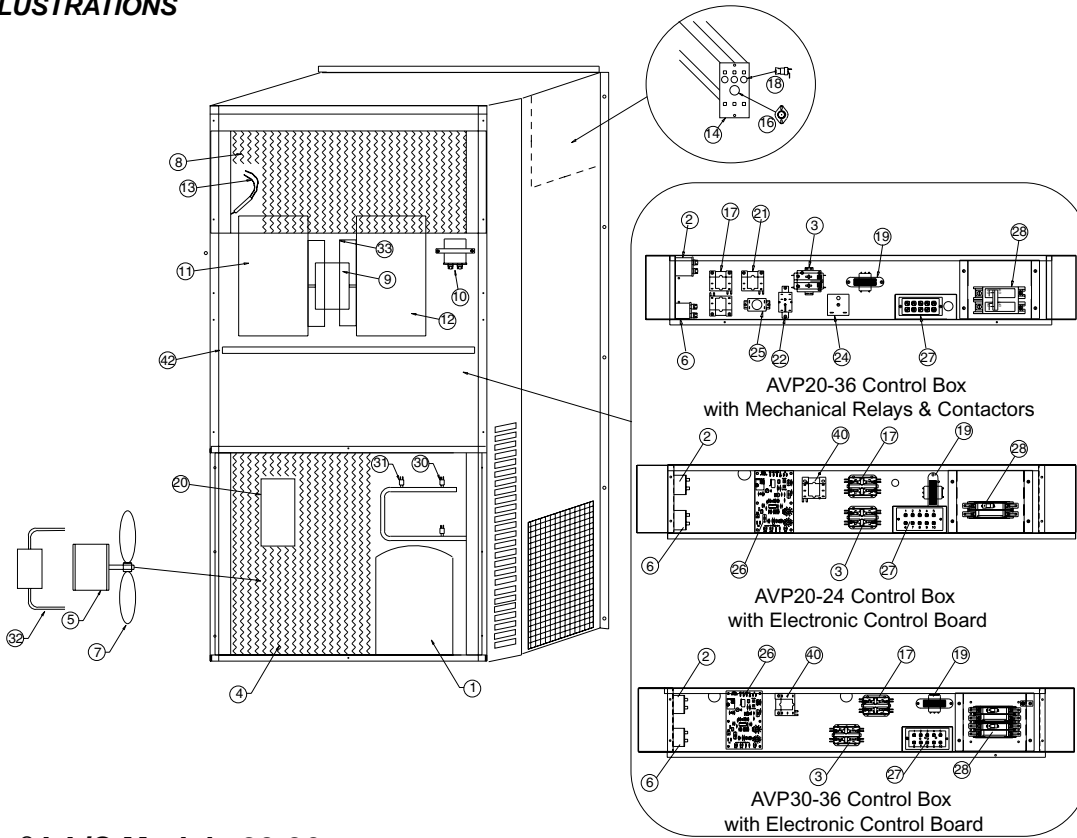

ComPac® I A/C Models 20-36

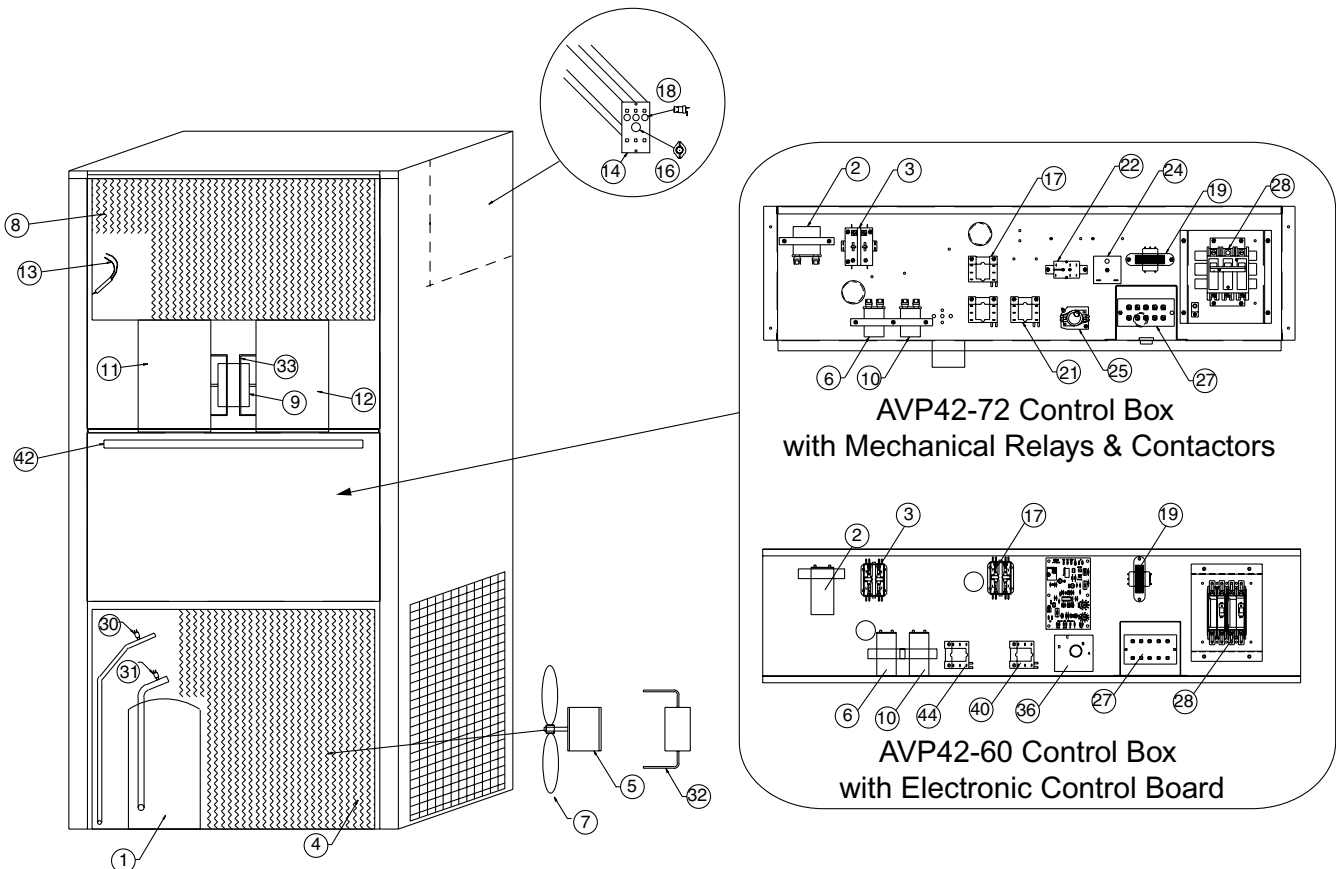

ComPac® I A/C Models 42-72

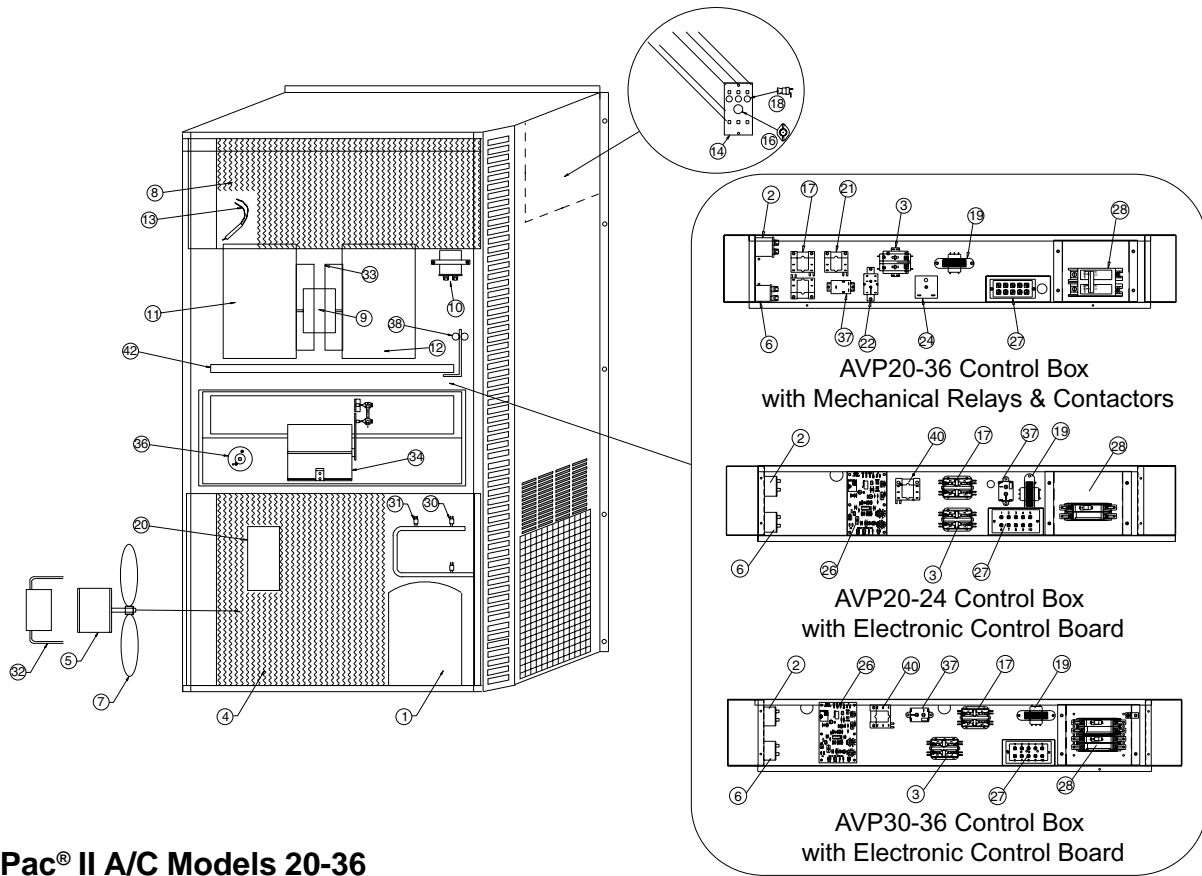

ComPac® II A/C Models 20-36

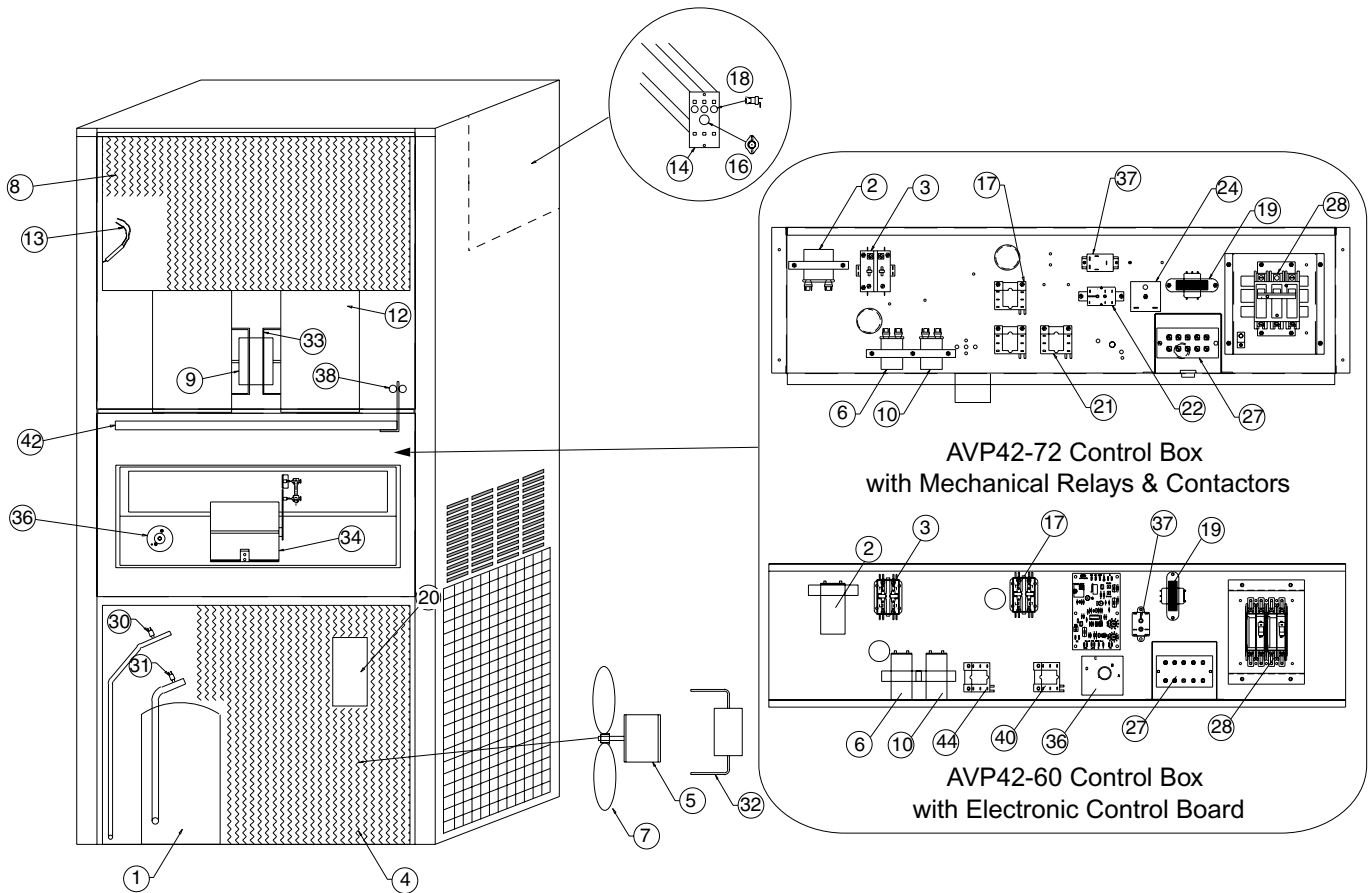

ComPac® II A/C Models 42-72

MAINTENANCE

6.1 SCHEDULED MAINTENANCE

Marvair® strongly recommends that the air conditioner be serviced a minimum of twice a year – once prior to the heating season and once prior to the cooling season. At this time the filters, evaporator coil, condenser coil, the cabinet, and condensate drains should be serviced as described below. Also at this time, the air conditioner should be operated in the cooling and heating cycles as described in Chapter 3, Start-Up. In addition to this seasonal check-out, the ComPac® A/C should be maintained as follows:

Air Filter

Replace the air filter whenever it is visibly dirty.

Evaporator

If the evaporator becomes clogged or dirty, it may be cleaned by careful vacuuming or with a commercial evaporator cleaning spray. **DO NOT** use a solvent containing bleach, acetone, or flammable substances. Turn off power before cleaning.. Be careful not to wet any of the electrical components. Be sure the unit has dried before restarting.

Condenser

Periodically inspect the outdoor condenser coil and the cabinet air reliefs for dirt or obstructions. Remove foreign objects such as leaves, paper, etc.

If the condenser coil is dirty, it may be washed off with a commercial solvent intended for this purpose. **TURN OFF POWER BEFORE CLEANING!** Be sure that all electrical components are thoroughly dry before restoring power.

Cabinet

The cabinet may be cleaned with a sponge and warm, soapy water or a mild detergent. Do not use bleach, abrasive chemicals or harmful solvents.

Drains

Regularly check the primary and secondary condensate drains. The secondary drain has a stand pipe (on AVP20-72). An obstruction will force water to dump into the middle of the unit and drain out the sides of the ComPac, causing discoloration of the side panels. If discoloration is noted, service the drains.

If a commercial drain solvent is used, flush out the drain pan and system with plenty of fresh water to prevent corrosion.

Lubrication

Under normal conditions, the condenser fan and evaporator blower motors have a five year supply of lubricant. However, if the unit is operated in a harsh environment, lubricate the bearings more frequently with SAE 20 weight non-detergent oil.

WARRANTY

7.1 LIMITED PRODUCT WARRANTY

If any part of your Marvair® Air Conditioner, Heat Pump or Unit Ventilator fails because of a manufacturing defect within fifteen months from the date of original shipment from Marvair or within twelve months from the date of original start-up, whichever is the earlier date, Marvair will furnish without charge, EXW Cordele, Georgia, the required replacement part. Any transportation, related service labor, diagnosis calls, filter, driers, and refrigerant are not included. The owner must provide proof of the date of the original start-up. The owner's registration card filed with Marvair, the contractor's invoice, the certificate of occupancy or similar document are examples of proof of the date of the original start-up.

In addition, if the hermetic compressor fails because of a manufacturing defect within sixty months from the date of original shipment from Marvair®, Marvair will furnish without charge, EXW Cordele, Georgia, the required replacement part. Any related service labor, diagnosis calls, filter, driers and refrigerant are not included. Marvair will pay for non-priority shipping costs of the compressor during the first twelve months of the warranty period. After the first twelve months of the warranty period, all costs of shipment and risk of loss during the shipment of the compressor shall be the responsibility of the owner.

The owner of the product may ship the allegedly defective or malfunctioning product or part to Marvair®, at such owner's expense, and Marvair will diagnose the defect and, if the defect is covered under this warranty, Marvair will honor its warranty and furnish the required replacement part. All costs for shipment and risk of loss during shipment of the product to Marvair and back to the owner shall be the responsibility and liability of the owner. Upon written request by an owner, Marvair may arrange for remote diagnosis of the allegedly defective or malfunctioning product or part but all costs for transportation, lodging and related expenses with regard to such diagnostic services shall be the responsibility and liability of the owner.

An owner requesting performance under this Warranty shall provide reasonable access to the allegedly defective or malfunctioning product or part to Marvair® and its authorized agents and employees.

This warranty applies only to products purchased and retained for use within the U.S.A., Canada, and Mexico. This warranty does not cover damage caused by improper installation, misuse of equipment or negligent servicing.

THIS WARRANTY CONSTITUTES THE EXCLUSIVE REMEDY OF ANY PURCHASER OF A MARVAIR® HEAT PUMP OR AIR CONDITIONER AND IS IN LIEU OF ALL OTHER WARRANTIES, EXPRESSED OR IMPLIED, INCLUDING, WITHOUT LIMITATION, ANY IMPLIED WARRANTY OF MERCHANTABILITY OR FITNESS FOR USE, TO THE FULLEST EXTENT PERMITTED BY LAW. IN NO EVENT SHALL ANY IMPLIED WARRANTY OF MERCHANTABILITY OR FITNESS FOR USE EXCEED THE TERMS OF THE APPLICABLE WARRANTY STATED ABOVE AND MARVAIR SHALL HAVE NO OTHER OBLIGATION OR LIABILITY. IN NO EVENT SHALL MARVAIR BE LIABLE FOR INCIDENTAL OR CONSEQUENTIAL DAMAGES OR MONETARY DAMAGES.

THIS WARRANTY GIVES YOU SPECIFIC LEGAL RIGHTS, AND YOU MAY ALSO HAVE OTHER RIGHTS WHICH VARY FROM STATE-TO-STATE. Some states do not allow limitations or exclusions, so the above limitations and exclusions may not apply to you.

Rev. 902
Supersedes 7/02

7.2 OPTIONAL



If any part of your Marvair® Heat Pump or Air Conditioner fails because of a manufacturing defect within fifteen months from the date of original shipment by Marvair or within twelve months from the date of original start-up, whichever is the earlier date, Marvair will furnish without charge, EXW Cordele, Georgia, the required replacement part and pay for the related service labor to replace the failed part. The owner must provide proof of the date of the original start-up. The owner's registration card filed with Marvair, the contractor's invoice, the certificate of occupancy or similar document are examples of proof of the date of the original start-up.

When service is required, it must be performed during normal working hours (8:00 a.m. to 5:00 p.m.) Monday through Friday and must be performed by Marvair® personnel or their designated Service Representative.

The responsibility of the Owner of the Equipment includes the following:

1. To operate the equipment according to the manufacturer's instructions.
2. To provide easy accessibility for service.
3. To check and reset circuit breaker(s) and disconnect before calling for service. (Circuit breaker(s) may be in the main service panel. The disconnect is in the Marvair® unit.)
4. To keep the unit clean and free of dirt.
5. To replace filters as required. (Filters are located in the lower front panel of the Marvair® unit below the indoor blower section.)
6. To keep the outdoor coil section clean and free of leaves, paper, etc.
7. To pay the charges incurred when any of the above have not been done.
8. To pay for repair or replacement of any material or part other than those within the Marvair® unit or thermostat itself.

In addition, if the hermetic compressor fails because of a manufacturing defect within the second through fifth year from the date of original shipment by Marvair®, Marvair will furnish without charge, EXW Cordele, Georgia, the required replacement. Any transportation, related service labor, diagnosis calls, filter, driers and refrigerant are not included.

The owner of the product may ship the allegedly defective or malfunctioning product or part to Marvair®, at such owner's expense, and Marvair will diagnose the defect and, if the defect is covered under this warranty, Marvair will honor its warranty and furnish the required replacement part. All costs for shipment and risk of loss during shipment of the product or part to Marvair and back to the owner shall be the responsibility and liability of the owner. Upon written request by an owner, Marvair may arrange for remote diagnosis of the allegedly defective or malfunctioning product or part but all costs for transportation, lodging and related expenses with regard to such diagnostic services shall be the responsibility and liability of the owner.

An owner requesting performance under this Warranty shall provide reasonable access to the allegedly defective or malfunctioning product to Marvair® and its authorized agents and employees.

This warranty only applies to products purchased and retained for use within the U.S.A. This warranty does not cover damage caused by improper installation, misuse of equipment or negligent servicing.

THIS WARRANTY AND SERVICE POLICY CONSTITUTE THE EXCLUSIVE REMEDY OF ANY PURCHASER OF A MARVAIR® HEAT PUMP OR AIR CONDITIONER AND IS IN LIEU OF ALL OTHER WARRANTIES, EXPRESSED OR IMPLIED, INCLUDING, WITHOUT LIMITATION, ANY IMPLIED WARRANTY OF MERCHANTABILITY OR FITNESS FOR USE, TO THE FULLEST EXTENT PERMITTED BY LAW. IN NO EVENT SHALL ANY IMPLIED WARRANTY OF MERCHANTABILITY OR FITNESS FOR USE EXCEED THE TERMS OF THE APPLICABLE WARRANTY STATED ABOVE AND MARVAIR SHALL HAVE NO OTHER OBLIGATION OR LIABILITY. IN NO EVENT SHALL MARVAIR BE LIABLE FOR INCIDENTAL OR CONSEQUENTIAL DAMAGES OR MONETARY DAMAGES.

THIS WARRANTY GIVES YOU SPECIFIC LEGAL RIGHTS, AND YOU MAY ALSO HAVE OTHER RIGHTS WHICH VARY FROM STATE-TO-STATE. Some states do not allow limitations or exclusions, so the above limitations and exclusions may not apply to you.

Rev. 9/02
Supersedes 7/02