

# Economite RE4700BA Series Power Gas Burners

The RE4700BA technology features a patent-pending retention head design which shapes the flame into an efficient and compact flame pattern. This design concentrates heat to the most efficient heat exchange surfaces.

Economite  
RE4700BA

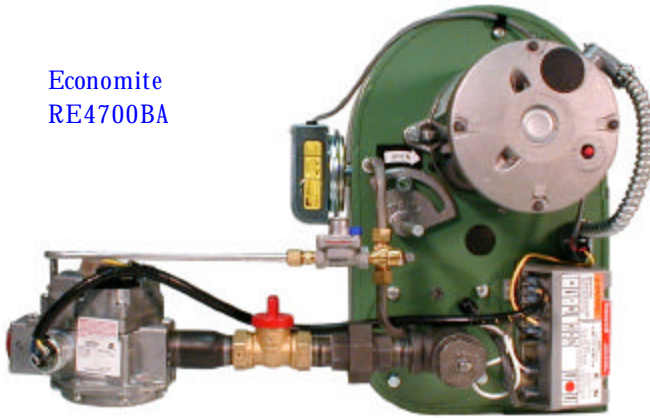

## Applications

The Economite, RE4700BA Series Power Gas Burner is engineered to serve a wide variety of applications or can be customized to accommodate the OEM's specific requirements.

Food Service Equipment  
Conveyor Ovens  
Rack Ovens  
Pressure Washers  
Commercial Dryers  
Furnaces  
Agricultural Processing

Water Heaters  
Heat Treatment  
Process Ovens  
Commercial Irons  
Crop Drying  
Boilers  
Space Heating

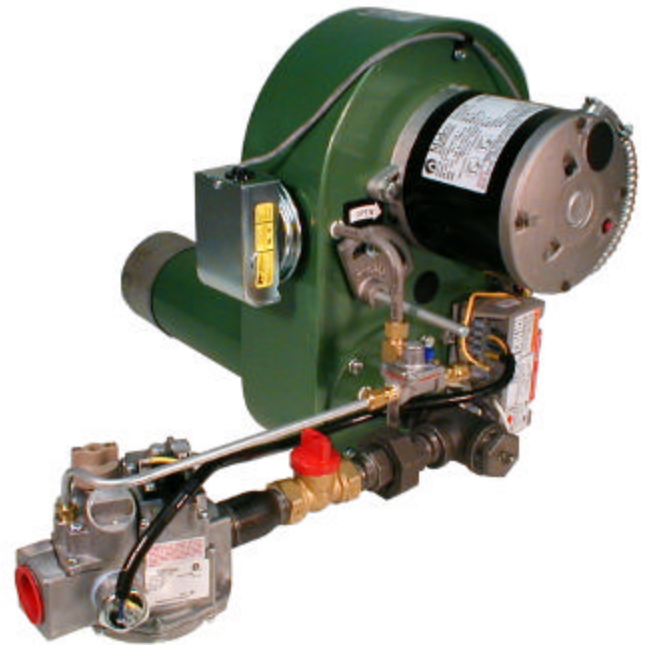

Economite RE4700BA

*Quality Designed for Proven Performance*

# Specifications

Model Number	Maximum Input Rating*	Minimum Input Rating*	Gas Connection Iron Pipe Size	Diameter of Nozzle	Maximum Nozzle Insertion Depth	Air Delivery (approx) at Zero Draft	Gas Pressure Required Natural or Propane	Motor Horsepower	Shipping Weight
RE4700BA	700,000*	230,000*	1"NPT	4"	8"	125 SCFM**	7.0" to 14.0" W.C	1/6	35lb

\*BTU/HR  
 \*\* SCFM -- Std Cubic Ft/Min  
 Available in Natural and LP  
 Electrical Supply 115 - 50/ 60,  
 Gas Burner Draft Motors  
 115V - 50/60 Hz  
 230V - 50/60Hz

The RE4700BA is available as a fully assembled power burner with control system. For further information please contact [Sales@midco-intl.com](mailto:Sales@midco-intl.com)

## Features & Benefits

The RE4700BA Technology . . .

- Provides more uniform heat throughout the length of the heat exchanger creating more consistent heat distribution characteristics.
- Universal Mounting Flange makes installation fast and easy. Welded flange assemblies are also available to accommodate OEM specifications.
- Patent pending burner design increases efficiency by reducing the volume of oxygen used for combustion.
- Bi-directional manifold and Compact Design allows OEMs to reduce their burner inventory.
- Sheet Metal Construction allows Midco high volume production resulting in most competitive pricing and shorter lead-time.

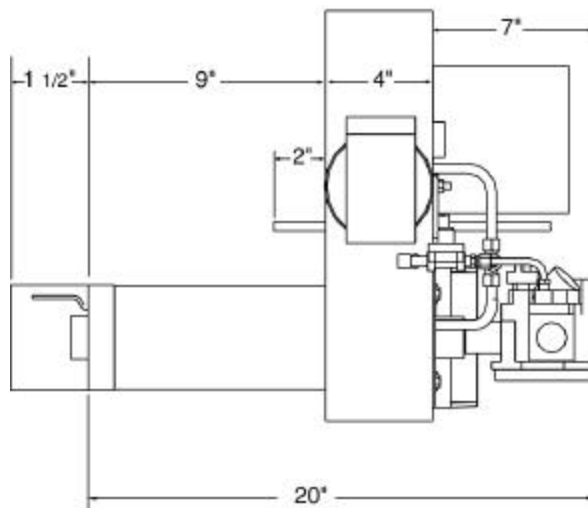

RE4700BA Side View

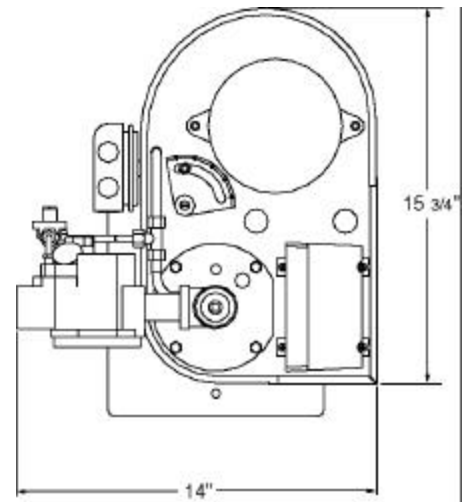

RE4700BA Rear View



**Midco**  
INTERNATIONAL

Midco® International Inc.  
 4140 West Victoria Street  
 Chicago, Illinois 60646  
 tel 773.604.8700  
 fax 773.604.4070  
 web [www.midco-intl.com](http://www.midco-intl.com)  
 email [sales@midco-intl.com](mailto:sales@midco-intl.com)