



MARSHALL ENGINEERED PRODUCTS CO.

PUMP SECTION

Centrifugal Pumps, Type RC05 and RC06 - Close Coupled, End Suction



**General Service Pumps
Flows to 120 GPM, 60 PSI
Horizontal 56J Frame**

FEATURES

1) **CASE** - Discharge can be located in any of four (4) positions. Back pull-out design eliminates the need to disturb piping. Material of construction, class 30 cast iron.

2) **IMPELLER** - Advanced impeller design for maximum hydraulic efficiency, dynamically balanced for vibration free operation.

3) **MECHANICAL SEAL** - Buna N shaft seal rated for

250 degrees Fahrenheit and pressures up to 175 PSI. ceramic seat and carbon seal face for long trouble free service. Alternative seals are available to suit temperatures and liquid.

4) **SHAFT/MOTOR** - One piece stainless steel threaded shaft and ball bearing construction in all open drip proof enclosures. Shaft and mounting flange comply with Nema standards allowing interchangeability.

MATERIALS OF CONSTRUCTION

ITEM	DESCRIPTION	MATERIAL	OPTION
1	CASE	CLASS 30 C.I.	BRONZE
2	ADAPTER	CLASS 30 C.I.	BRONZE
3	IMPELLER	BRONZE	CAST IRON
4	MECH. SEAL	BUNA N	EPT/VITON
5	O-RING	BUNA N	EPT/VITON
6,7	BOLTS	STEEL	
8	PIPE PLUG	STEEL	BRONZE
9	MOTOR	NEMA (ODP)	TEFC/XPROOF
10	WASHER	SST	BRASS
11	CAP SCREW	SST	MONEL
12	BASE	STEEL	

MAXIMUM OPERATING CONDITIONS

Based on Std. Construction & Pumping Clear Water

RPM -	3450
HORSEPOWER -	3
STD. SEAL TEMP. -	250 DEGREES FAHRENHEIT
OPT. SEAL TEMP.	300° F = EPT, 400° F = VITON
MODEL R5, R6 -	125 LB. FLANGES
MAX. WORKING PRESS. -	175 PSI
HYDROSTATIC	
TEST PRESSURE -	265 PSI

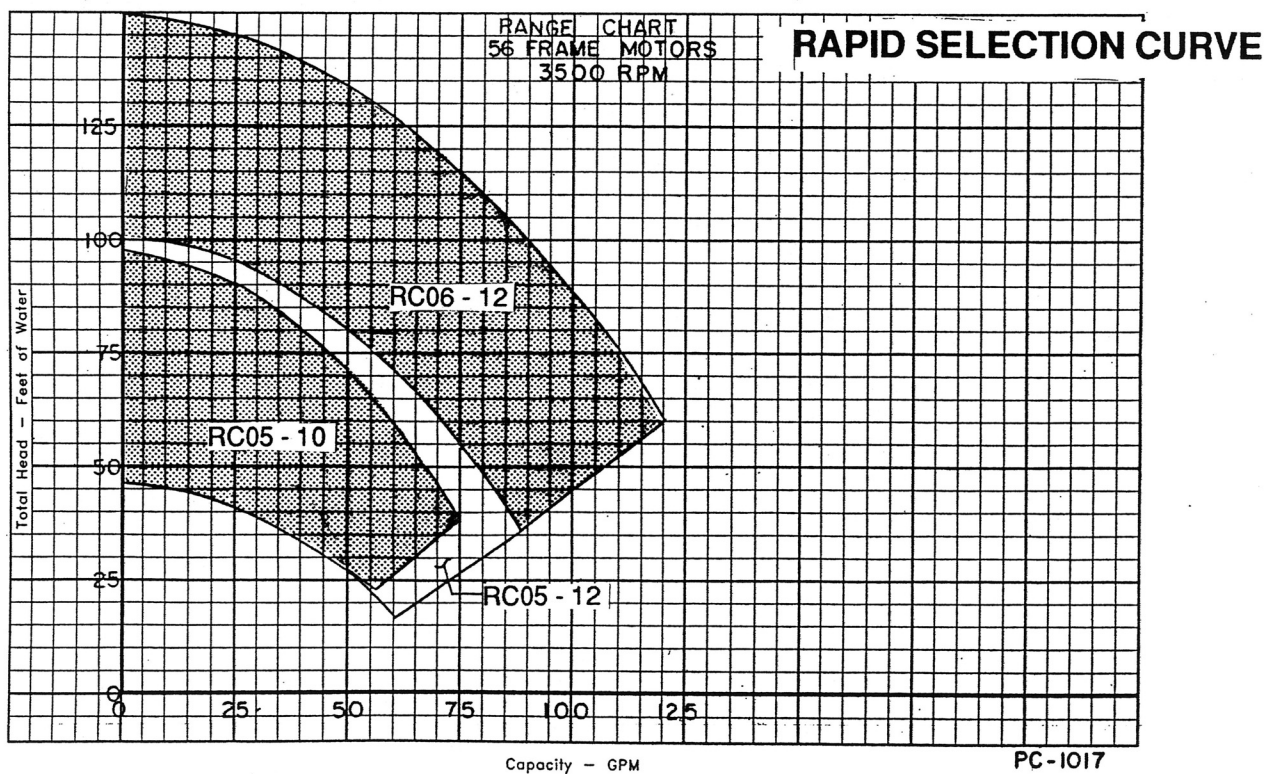
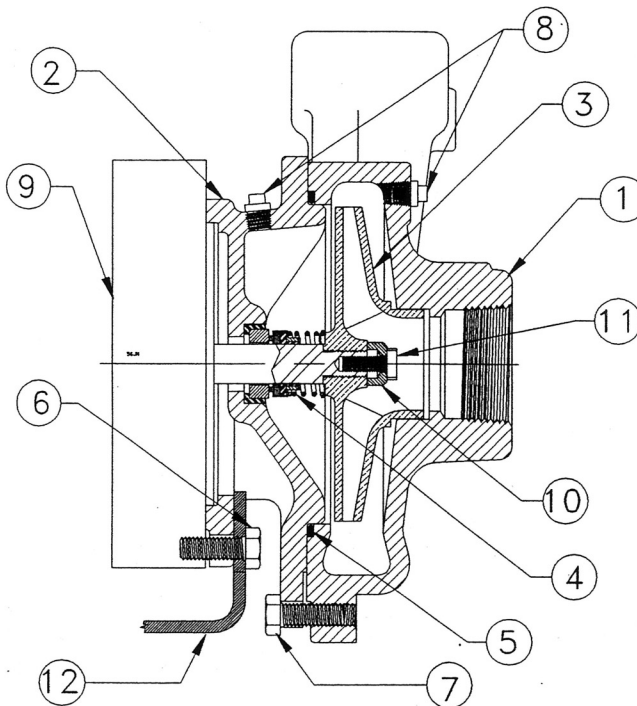

DIMENSIONS

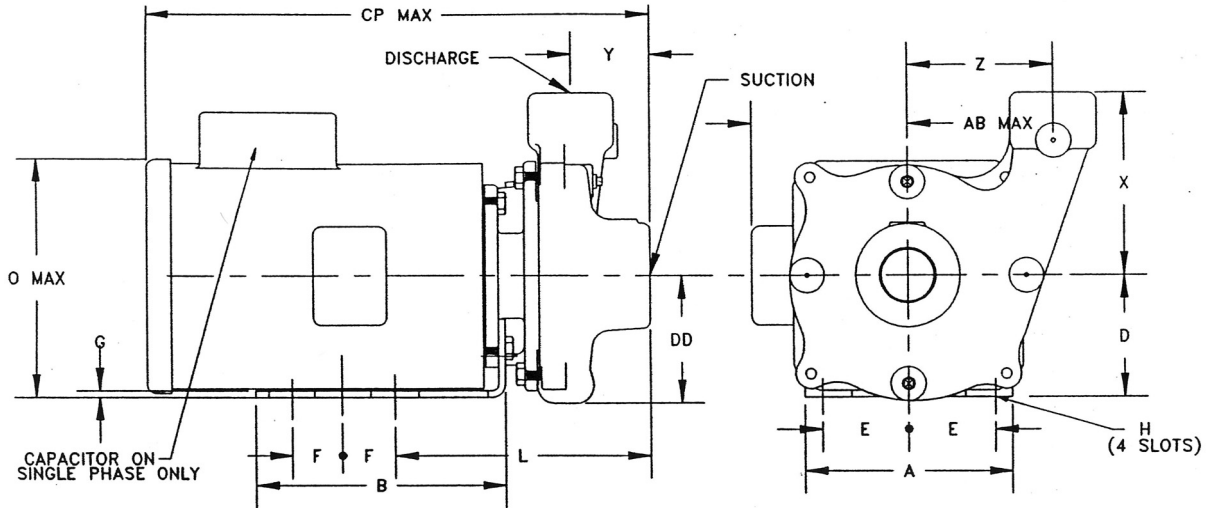

PUMP	MOTOR FRAME SIZE	DISC. NPT	SUCT. NPT	DIMENSIONS IN INCHES														
				A	B	AB	CP	D	DD	E	F	G	H	L	O	X	Y	Z
RC05 - 10	56J	1	1 1/4	6	7 1/4	5 1/4	16 1/4	3 1/2	3 5/8	2 7/16	1 1/2	3/16	1 X 3/8	7 7/16	6 7/8	5 5/16	2 3/8	4
RC05 - 12	56J	1 1/4	1 1/2	6	7 1/4	5 1/4	16 1/4	3 1/2	3 5/8	2 7/16	1 1/2	3/16	1 X 3/8	7 7/16	6 7/8	5 5/16	2 1/4	4 1/4
R6-1 1/4	56J	1 1/4	1 1/2	6	7 1/4	5 1/4	16 1/4	3 1/2	4 1/4	2 7/16	1 1/2	3/16	1 X 3/8	8 1/4	6 7/8	5 1/2	3	4 7/16

TYPICAL SPECIFICATIONS

- Furnish and install pumps with capacities as shown on plans. Pumps shall be close coupled, single-stage, vertically-split case design, capable of being serviced without disturbing piping. Pump volute shall be Class 30 cast iron and impeller shall be brass enclosed type, dynamically balanced.
- Seal shaft shall be of rotary type and suitable for water temperatures up to 250 degrees Fahrenheit.
- Pumps shall be rated for minimum of 175 psi working pressure. Casings shall have vent and drain ports at top and bottom.
- Motor shall meet NEMA specifications and shall be of the size, voltage and enclosure called for on the plans. It shall have heavy-duty sealed ball bearings, stainless steel shaft, adequate for the maximum load for which the motor is designed. Each pump shall be factory tested. It shall then be thoroughly cleaned and painted with at least one coat of high-grade lacquer prior to shipment.
- Each pump shall be checked by contractor and regulated for proper pressure, voltage and amperage draw. Data shall be noted on a tag or label and fastened to pump for reference. Pumps shall be Series RC05 or RC06 as manufactured by MEPCO.

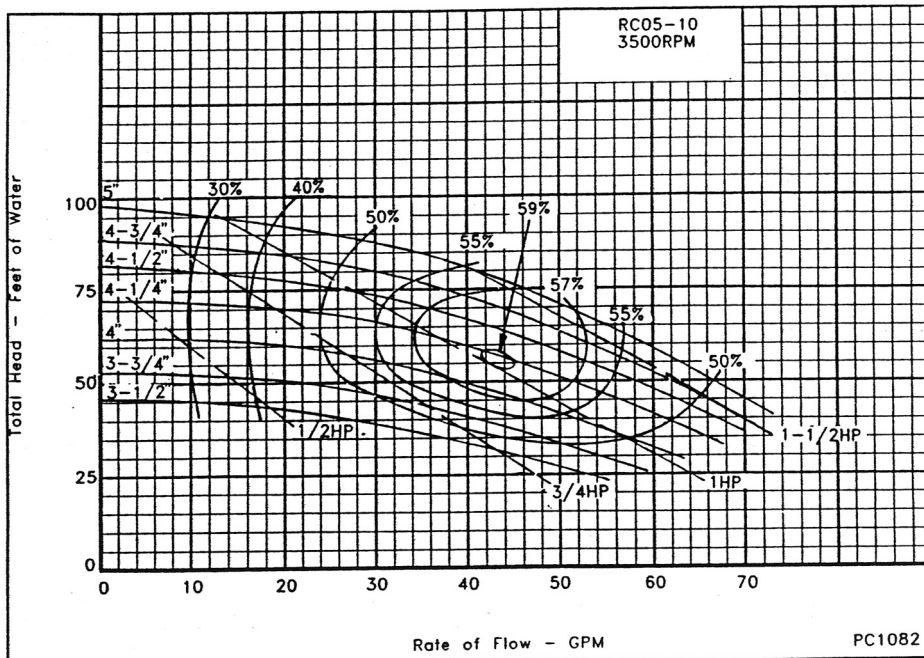

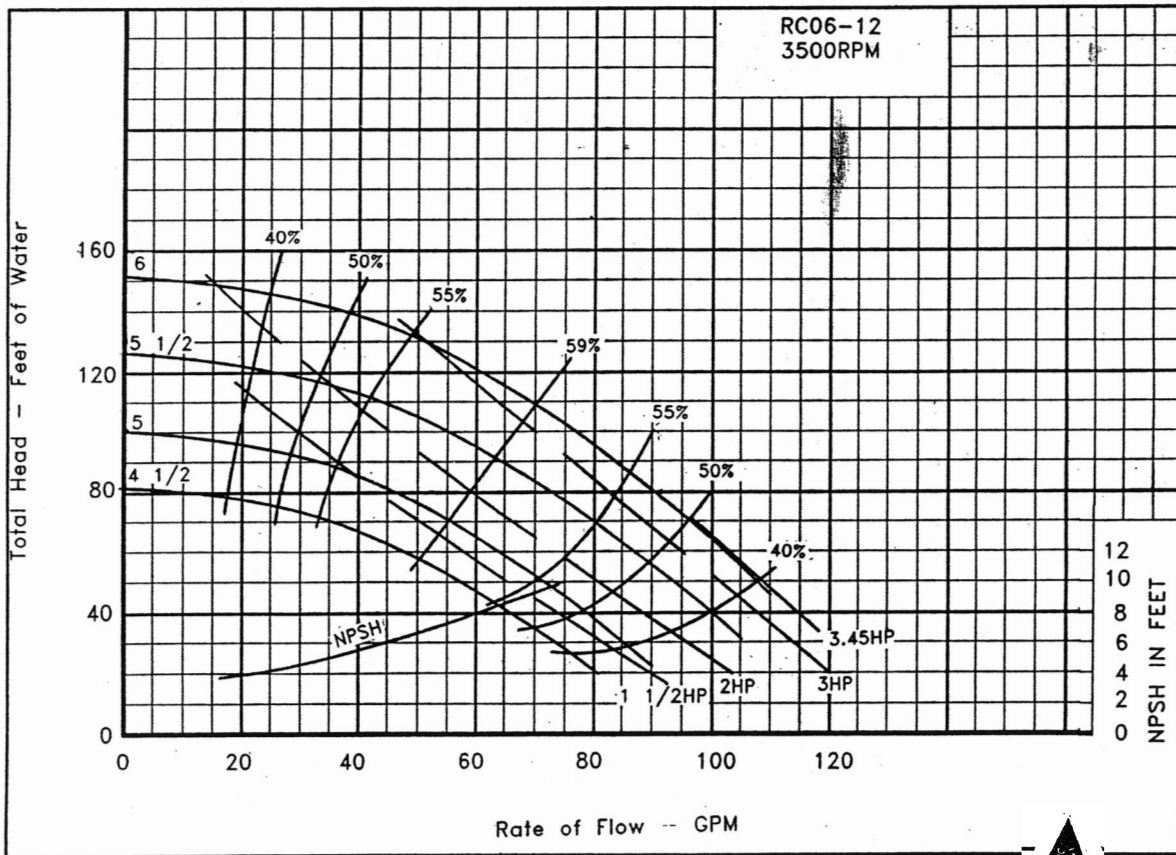
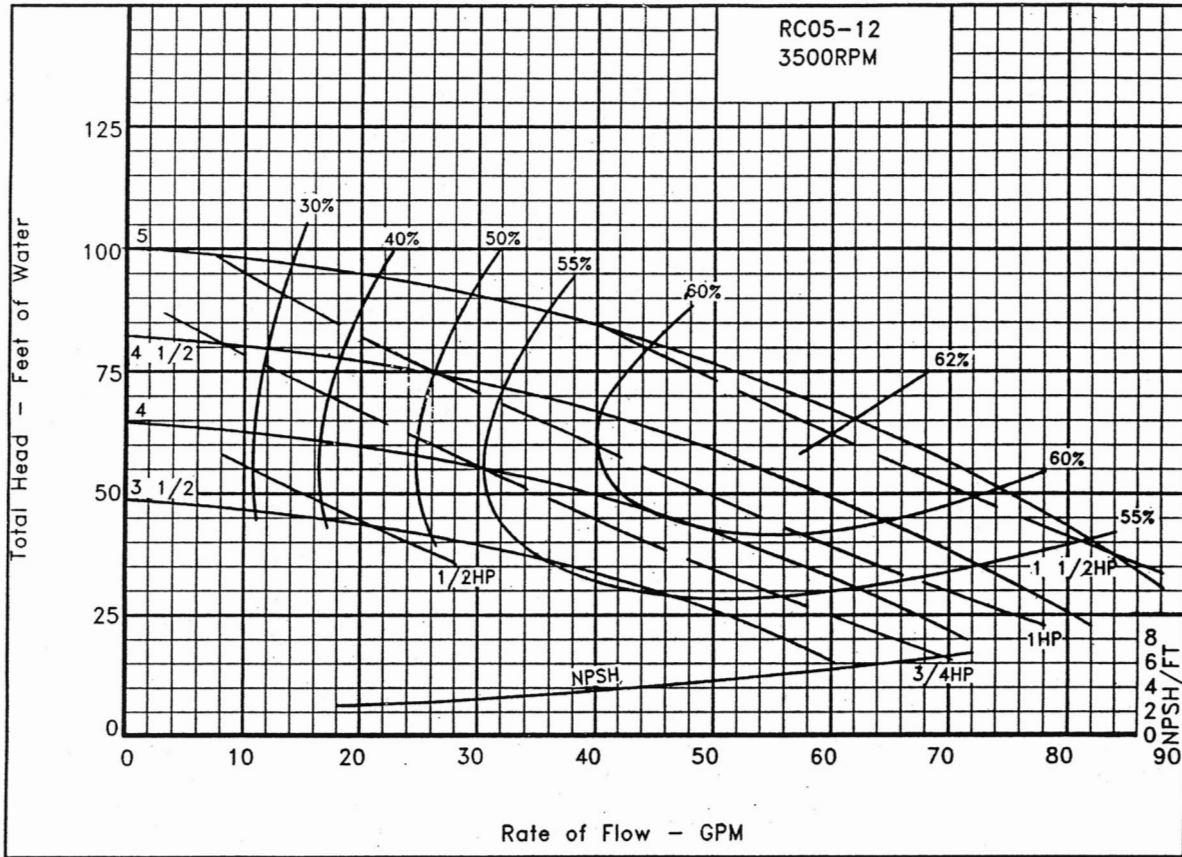

MARSHALL ENGINEERED PRODUCTS CO.

3056 Walker Ridge Drive, Suite C, Grand Rapids, Michigan 49544
Phone 616.246.1431 Fax 616.246.1445 www.mepcollc.com

