

# SERVICE AND APPLICATION NOTES

May 15, 2013  
C-13-05

## ECB29-12.5 and 15kw Electric Heat Sections Matched with CB29M-31 Air Handlers

**Affected Units:** CB29M-31 air handlers matched with ECB29-12.5 and 15kw electric heat sections.

**Issue:** Field reports of replacement electric heat solutions not fitting in available opening.

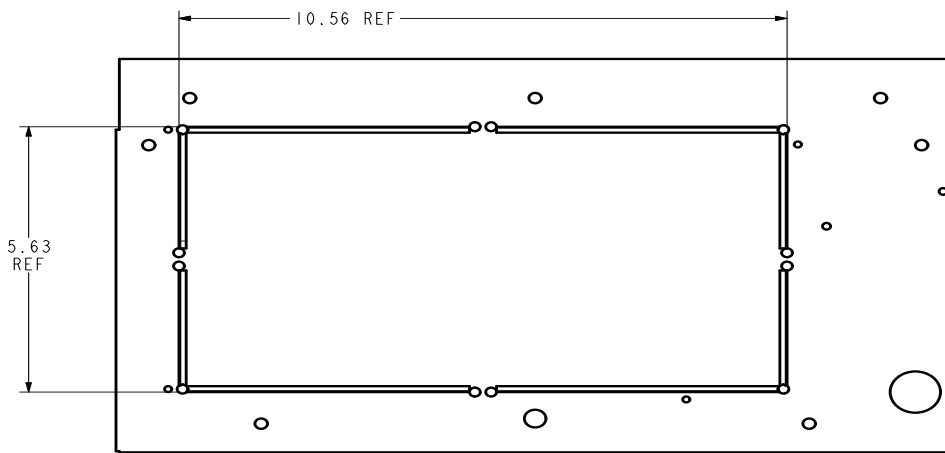

**CB29M-31 electric heat section opening width is 10.56"**

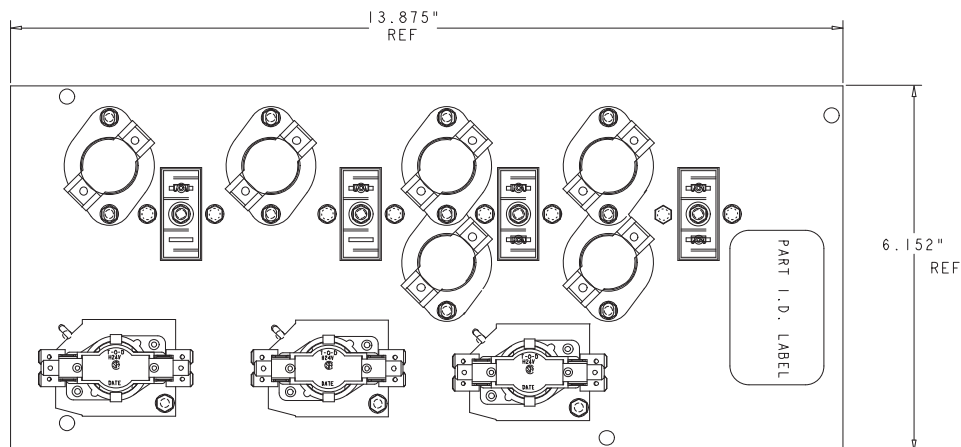

**Mounting plate width is 13.875" on current ECB29-12.5 and 15kw electric heat sections**

**Solution:** Order replacement components (electric elements, sequencing relays, etc.) as needed, to repair the existing electric heat section. Electric heat sections currently being produced will not fit.