

FENWAL®

Effective: October 1996

SERIES 30000**SURFACE MOUNTING THERMOSWITCH®
TEMPERATURE CONTROLLERS
INSTALLATION INSTRUCTIONS****PRINCIPLE OF OPERATION**

The Series 30000 Surface Mounting THERMOSWITCH® Controller consists of a stainless steel case (1) and cover welded together to form a one piece unit. See Figure 1. The low expansion metal bridge (4) is welded to each end of the bottom of the case. An increase in temperature causes the case to expand, lengthening the bridge and causing its downward motion. The bridge normally holds the spring-biased contact supporting members (3) in a closed position. The motion of the bridge permits the contacts (2) to break when the required temperature is reached.

TEMPERATURE ADJUSTMENT

Temperature adjustment is made by rotating the adjusting screw (8). Turning the screw clockwise increases the temperature setting. A stop collar (7) prevents turning the adjustment screw in excess of the THERMOSWITCH Controller high temperature limit. Controllers containing Modification 53 have a second stop collar set at a customer specified high or low temperature setting.

All standard controllers, except those set at the factory (Modification 52) and those with a locking screw (Modification 55), are furnished with a constant torque spring (11). The spring is located under the adjusting screw yoke to provide pressure against the adjusting screw (8), resulting in a smooth screw adjustment and constant torque.

LOCKING SCREW (MODIFICATION 55)

When a controller is factory set at a requested temperature or is ordered with Modification 55, it comes with a socket head screw (12) in the adjustment screw yoke. When tightened, the locking screw provides a friction lock on the adjusting screw.

Temperature setting on controllers containing the locking screw should be done as follows:

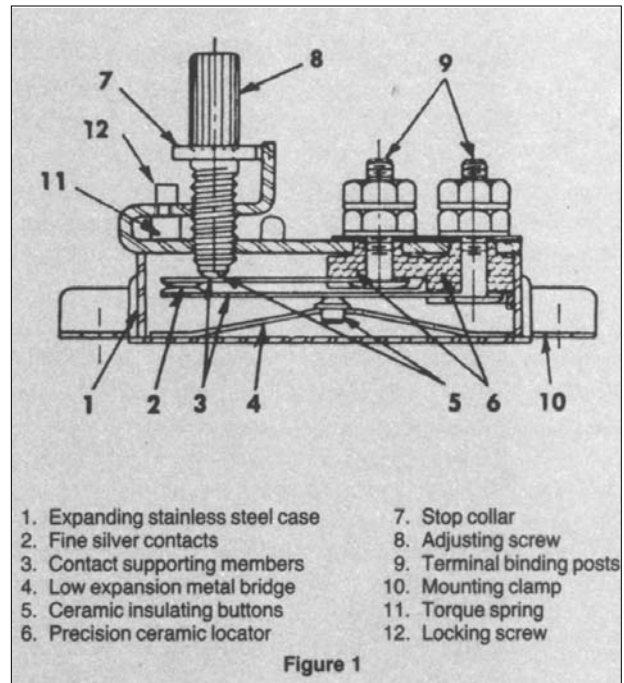

Figure 1

1. Turn the adjusting screw (8) to achieve the approximate temperature setting.
2. Tighten the locking screw (12) to secure a high torque but not enough to prevent further adjustment.
3. Make the final adjustment by turning the adjustment screw.

CAUTION

Never make the final adjustment prior to tightening the locking screw. The temperature setting will shift when the locking screw is tightened.

**LOCKING SCREW AND TORQUE SPRING
(MODIFICATION 55A)**

This modification enables the user to adjust the temperature setting and to also lock it in place. The temperature adjustment procedure is the same as in the preceding section.

SURFACE MOUNTING THERMOSWITCH CHARACTERISTICS

Catalog Number	Approximate Temperature Range	Approximate F° per Full Turn of Adj. Screw	Current Rating	Contact Operation on Temperature Rise
30000-0	50-300°F	250	10 Amps, 120 VAC 5 Amps, 240 VAC	Open
30000-48	85-250°F	175		
30002-0	50-600°F	575		

Recognized under the Component Program of Underwriters Laboratories, Inc.
File #E 18974

Certified by Canadian Standards Association
File #LR 7378

MOUNTING

Use the "C"-shaped mounting clamp, shown in Figure 2, to side or bottom mount the THERMOSWITCH Controller to a flat surface. The mounting bracket also serves to permit free expansion of the case if there is a differential between the case and the device to which it is clamped.

In certain instances, the "C"-shaped mounting bracket cannot be used. In these cases, one of the two cross-type brackets (Modification 62 and 62A), shown in Figures 3A and 3B, may have been ordered.

The controller is designed for bottom mounting. Side bracket mounting will give satisfactory results but will not provide the equivalent sensitivity obtained by bottom mounting.

Mount the controller on a surface that is as flat, smooth, and clean as possible. Such surfaces provide better heat transfer and therefore better control.

Ambient temperature of the surrounding medium will affect the operation of the controller. Figures 4A, 4B, and 4C illustrate three ways the controller might be mounted in order of increasing efficiency. Additional efficiency can be gained by covering the top of the controller with an insulating material for additional protection from drafts and external ambient temperatures.

In certain instances, it may be desirable to have a temperature differential between the operating temperature of the controller and that of the medium. A temperature differential or lag may be obtained by placing insulating material between the controller and the surface to which it is clamped. See Figure 4A.

ELECTRICAL CONNECTIONS

Do not apply more than 10 in·lb (1.1 N·m) torque on terminal nuts.

OUTLINE DIMENSIONS

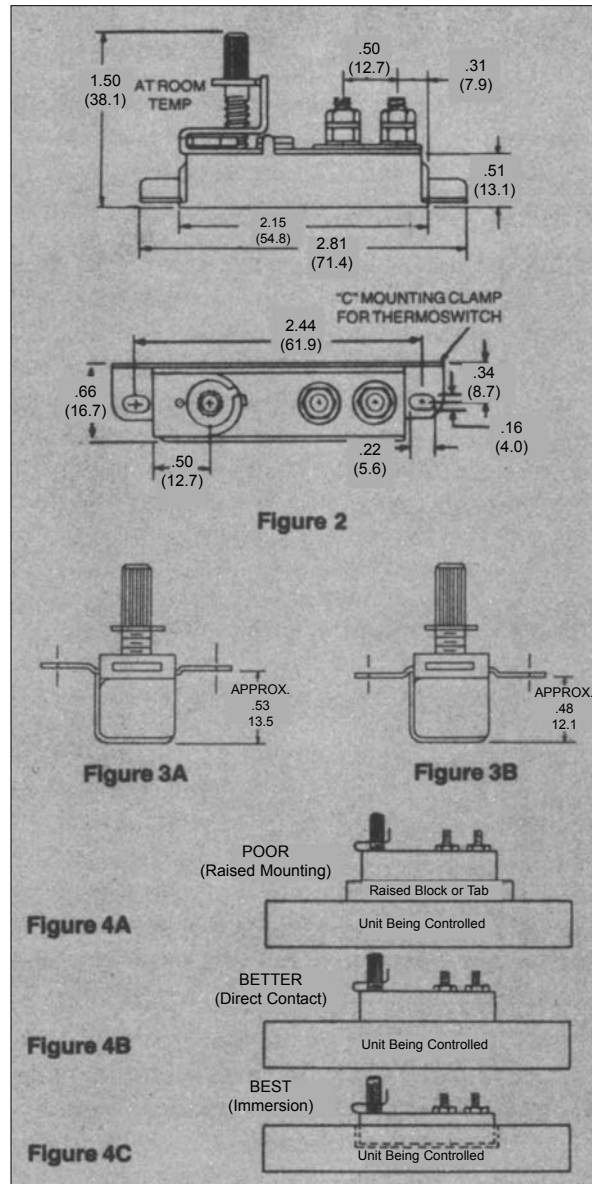

LIMITED WARRANTY STATEMENT

Kidde-Fenwal, Inc. represents that this product is free from defects in material and workmanship, and it will repair or replace any product or part thereof which proves to be defective in workmanship or material for a period of twelve (12) months from the date of purchase but not to exceed eighteen (18) months after shipment by the manufacturer. For a full description of Kidde-Fenwal's LIMITED WARRANTY, which, among other things, limits the duration of warranties of MERCHANTABILITY and FITNESS FOR A PARTICULAR PURPOSE and EXCLUDES liability for CONSEQUENTIAL DAMAGES, please read the entire LIMITED WARRANTY on the Kidde-Fenwal Quotation, Acceptance of Order and/or Original Invoice which will become part of your sales agreement. Please contact Kidde-Fenwal directly for a return material authorization (RMA) number before returning material to the factory at Ashland, Massachusetts, shipment prepaid. Kidde-Fenwal will repair or replace and ship prepaid.

FENWAL®

KIDDE-FENWAL, INC.
400 MAIN STREET, ASHLAND, MA 01721
TEL: (508) 881-2000 FAX: (508) 881-8920

This literature is provided for informational purposes only. KIDDE-FENWAL, INC. assumes no responsibility for the product's suitability for a particular application. This product must be properly applied to perform as described herein.

If you need more information on this product, or if you have a question, contact KIDDE-FENWAL, INC., Ashland, MA 01721. (508) 881-2000.