

Spyder[®] BACnet[®] Programmable Controllers

INSTALLATION INSTRUCTIONS

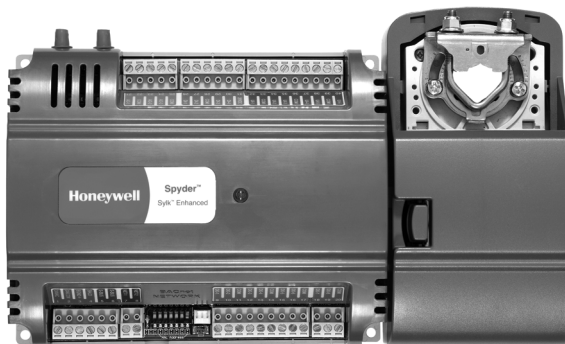

PRODUCT DESCRIPTION

The PUB and PVB controllers are part of the Spyder family. These controllers are BACnet MS/TP network devices designed to control HVAC equipment. These controllers provide many options and advanced system features that allow state-of-the-art commercial building control. Each controller is programmable and configurable through software.

These controllers are for use in VAV (Variable Air Volume), Unitary, and advanced HVAC applications. Each controller has flexible, universal inputs for external sensors, digital inputs, and a combination of analog and digital Triac outputs. All the models are described in Table 1. The photo to the left is the model PVB6436AS, which includes the actuator.

Table 1. Controller configurations.

Controller Model	Programmable Type	Universal Inputs (UI)	Digital Inputs (DI)	Analog Outputs (AO)	Digital Outputs (DO)	Velocity Pressure Sensor (Microbridge)	Series 60 Floating Actuator
PUB1012S	Unitary	1 ^a	0	1	2	NO	NO
PUB4024S	Unitary	4 ^a	0	2	4	NO	NO
PUB6438S	Unitary	6	4	3	8	NO	NO
PVB000AS	VAV	0	0	0	0	YES	YES
PVB4022AS	VAV	4 ^a	0	2	2	YES	YES
PVB4024NS	VAV	4 ^a	0	2	4	YES	NO
PVB6436AS	VAV	6	4	3	6	YES	YES
PVB6438NS	VAV	6	4	3	8	YES	NO

Each controller communicates via an EIA-485 BACnet MS/TP network communications network, capable of baud rates between 9.6 and 115.2 kilobits.

Controllers are field-mountable to either a panel or a DIN rail.

SPECIFICATIONS

General Specifications

Rated Voltage: 20–30 Vac; 50/60 Hz

Power Consumption:

100 VA for controller and all connected loads (including the actuator on models models PVL0000AS, PVL4022AS, and PVL6436AS).

Controller Only Load: 5 VA maximum; models PUB1012S, PUB4024S, PUB6438S, PVB4024NS, and PVB6438NS.

Controller and Actuator Load: 9 VA maximum; models PVL0000AS, PVL4022AS, and PVL6436AS.

External Sensors Power Output: 20 Vdc ±10% @ 75 mA maximum.

VAV Operating & Storage Temperature Ambient Rating (models PVB0000AS, PVB4022AS, PVB4024NS, PVB6436AS, and PVB6438NS):

Minimum 32 °F (0 °C); Maximum 122 °F (50 °C)

Unitary Operating & Storage Temperature Ambient Rating (models PUB1012S, PUB4024S, and PUB6438S):

Minimum -40 °F (-40 °C); Maximum 150 °F (65.5 °C)

Relative Humidity: 5% to 95% non-condensing

LED: Provides status for normal operation, controller down-load process, alarms, manual mode, and error conditions



BEFORE INSTALLATION

The controller is available in three models (see Table 1).

Review the power, input, and output specifications on page 1 before installing the controller.

- Hardware driven by Triac outputs must have a minimum current draw, when energized, of 25 mA and a maximum current draw of 500 mA.
 - Hardware driven by the analog current outputs must have a maximum resistance of 550 Ohms, resulting in a maximum voltage of 11 volts when driven at 20 mA.
- If resistance exceeds 550 Ohms, voltages up to 18 Vdc are possible at the analog output terminal.

⚠ WARNING

Electrical Shock Hazard.

Can cause severe injury, death or property damage.

Disconnect power supply before beginning wiring or making wiring connections to prevent electrical shock or equipment damage.

INSTALLATION

The controller must be mounted in a position that allows clearance for wiring, servicing, removal, connection of the BACnet MS/TP Molex connector and access to the MS/TP MAC address DIP switches.

The controller may be mounted in any orientation.

IMPORTANT

Avoid mounting in areas where acid fumes or other deteriorating vapors can attack the metal parts of the controller, or in areas where escaping gas or other explosive vapors are present. Fig. 6–Fig. 7 on page 4 for mounting dimensions.

For the PVB6436AS model, the actuator is mounted first and then the controller is mounted. For the other models, go to “When the actuator closes, the damper rotates CW either 45 or 60 degrees to fully close.” on page 3 to begin the installation.

Mount Actuator onto Damper Shaft (PVB000AS, PVB4022AS, and PVB6436AS)

PVB000AS, PVB4022AS, and PVB6436AS controllers include the direct-coupled actuator with Declutch mechanism, which is shipped hard-wired to the controller.

The actuator mounts directly onto the VAV box damper shaft and has up to 44 lb-in. (5 Nm) torque, 90-degree stroke, and 90 second timing at 60 Hz. The actuator is suitable for mounting onto a 3/8 to 1/2 in. (10 to 13 mm) square or round VAV box damper shaft. The minimum VAV box damper shaft length is 1-9/16 in. (40 mm).

The two mechanical end-limit set screws control the amount of rotation from 12° to 95°. These set screws must be securely fastened in place. To ensure tight closing of the damper, the shaft adapter has a total rotation stroke of 95° (see Fig. 1).

NOTES:

1. The actuator is shipped with the mechanical end-limit set screws set to 95 degrees of rotation. Adjust the two set screws closer together to reduce the rotation travel. Each “hash mark” indicator on the bracket represents approximately 6.5° of rotation per side.
2. The Declutch button, when pressed, allows you to rotate the universal shaft adapter (see Fig. 1).

IMPORTANT

Determine the damper rotation and opening angle prior to installation. See Fig. 2 below and Fig. 3 on page 3 for examples.

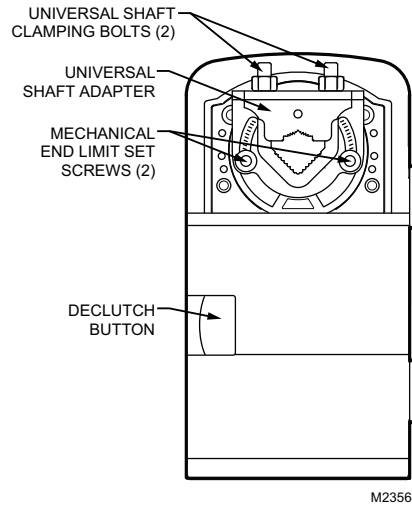

M23568

Fig. 1. Series 60 Floating Actuator.

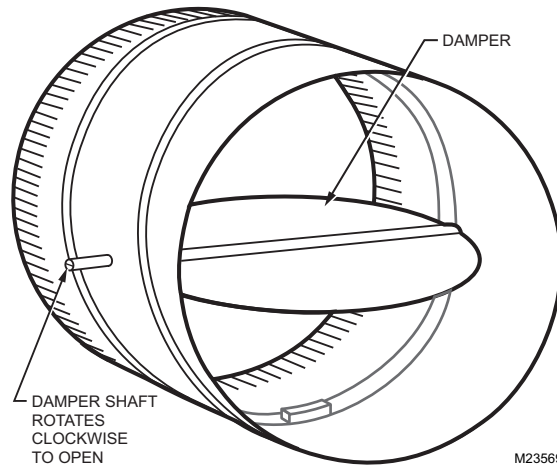

M23569

Fig. 2. Damper with 90 degree CW rotation to open.

IMPORTANT

Mount actuator flush with damper housing or add a spacer between the actuator mounting surface and damper box housing.

Before Mounting Actuator onto Damper Shaft (PVB0000AS, PVB4022AS, and PVB6436AS.)

Tools required:

- Phillips #2 screwdriver - end-limit set screw adjustment
- 8 mm wrench - centering clamp

Before mounting the actuator onto the VAV box damper shaft, determine the following:

1. Determine the damper shaft diameter. It must be between 3/8 in. to 1/2 in. (10 to 13 mm).
2. Determine the length of the damper shaft. If the length of the VAV box damper shaft is less than 1-9/16 in. (40 mm), the actuator cannot be used.
3. Determine the direction the damper shaft rotates to open the damper (CW or CCW) (see Fig. 3). Typically, there is an etched line on the end of the damper shaft that indicates the position of the damper. In Fig. 2, the indicator shows the damper open in a CW direction.
4. Determine the damper full opening angle (45, 60, or 90 degrees). In Fig. 2, the damper is open to its full open position of 90 degrees.

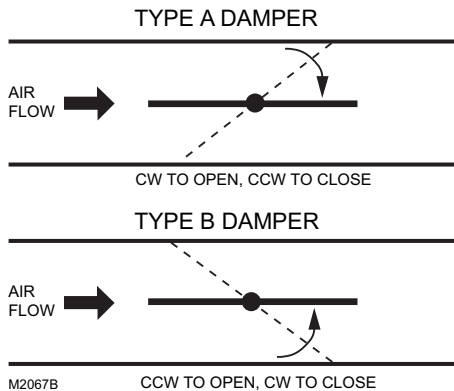

Fig. 3. Determining the rotation direction (CW or CCW) for damper opening.

Mounting Actuator onto Damper Shaft (PVB0000AS, PVB4022AS, and PVB6436AS.)

The unit is shipped with the actuator set to rotate open in the clockwise (CW) direction to a full 95 degrees. The extra 5 degrees ensures a full opening range for a 90 degree damper. The installation procedure varies depending on the damper opening direction and angle:

1. If the damper rotates clockwise (CW) to open, and the angle of the damper open-to-closed is 90 degrees:
 - a. Manually open the damper fully (rotate clockwise).
 - b. Using the Declutch button, rotate the universal shaft adapter fully clockwise.
 - c. Mount the actuator to the VAV damper box and shaft.

- d. Tighten the two bolts on the centering clamp (8 mm wrench; 70.8–88.5 lb-in. [8–10 Nm] torque). When the actuator closes, the damper rotates CCW 90 degrees to fully close.
2. If the damper rotates clockwise (CW) to open, and the angle of the damper open-to-closed is 45 or 60 degrees:
 - a. Manually open the damper fully (rotate clockwise).
 - b. The actuator is shipped with the mechanical end-limits set at 95 degrees. Adjust the two mechanical end-limit set screws to provide the desired amount of rotation. Adjust the two set screws closer together to reduce the rotation travel.
 - c. Tighten the two mechanical end-limit screws (Phillips #2 screwdriver; (26.5–31 lb-in. [3.0–3.5 Nm] torque).
 - d. Using the Declutch button, rotate the universal shaft adapter fully clockwise.
 - e. Mount the actuator to the VAV damper box and shaft.
 - f. Tighten the two bolts on the centering clamp (8 mm wrench; 70.8–88.5 lb-in. [8–10 Nm] torque).
 - g. When the actuator closes, the damper rotates CCW either 45 or 60 degrees to fully close.
3. If the damper rotates counterclockwise (CCW) to open, and the angle of the damper open-to-closed is 90 degrees:
 - a. Manually open the damper fully (rotate counterclockwise).
 - b. Using the Declutch button, rotate the universal shaft adapter fully counterclockwise.
 - c. Mount the actuator to the damper box and shaft.
 - d. Tighten the two bolts on the centering clamp (8 mm wrench; 70.8–88.5 lb-in. [8–10 Nm] torque). When the actuator closes, the damper rotates CW 90 degrees to fully close.
4. If the damper rotates counterclockwise to open, and the angle of the damper open-to-closed is 45 or 60 degrees:
 - a. Manually open the damper fully (rotate counterclockwise).
 - b. The actuator is shipped with the mechanical end-limits set at 95 degrees. Adjust the two mechanical end-limit set screws to provide the desired amount of rotation. Adjust the two set screws closer together to reduce the rotation travel.
 - c. Tighten the two mechanical end-limit screws (Phillips #2 screwdriver; (26.5–31 lb-in. [3.0–3.5 Nm] torque).
 - d. Using the Declutch button, rotate the universal shaft adapter fully counter-clockwise.
 - e. Mount the actuator to the VAV damper box and shaft.
 - f. Tighten the two bolts on the centering clamp (8 mm wrench; 70.8–88.5 lb-in. [8–10 Nm] torque).
 - g. When the actuator closes, the damper rotates CW either 45 or 60 degrees to fully close.

Mount Controller

NOTE: The controller may be wired before mounting to a panel or DIN rail.

Terminal blocks are used to make all wiring connections to the controller. Attach all wiring to the appropriate terminal blocks (see “Wiring” on page 5).

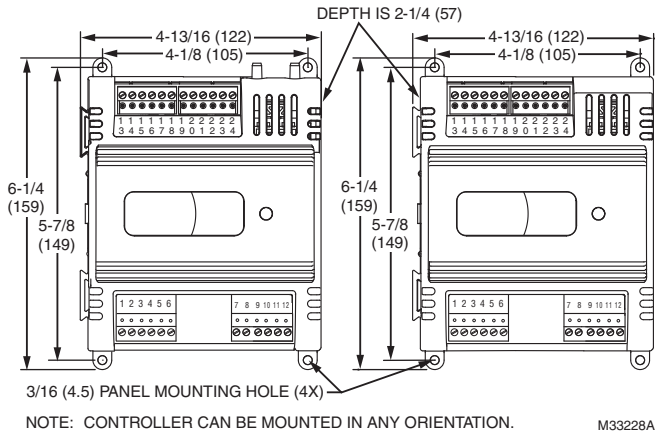

Fig. 4. Panel Mounting - controller dimensions in inches (mm) for PUB1012S, PUB4024S, and PVB4024NS (only PUB40245S and PVB4024NS shown).

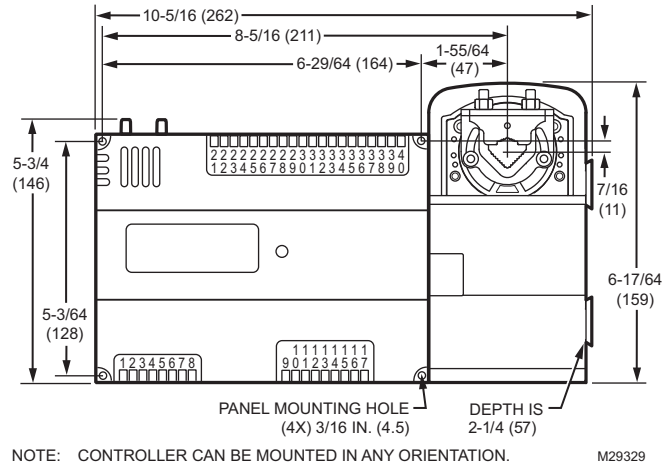

Fig. 6. Panel mounting - controller and actuator dimensions in inches (mm) for PVB6436AS.

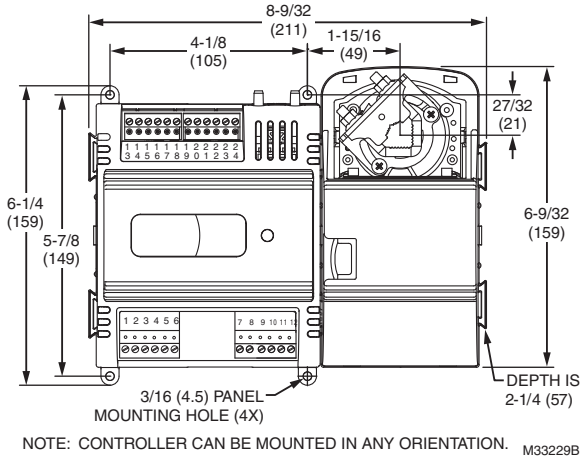

Fig. 5. Panel mounting - controller and actuator dimensions in inches (mm) for PVB000AS and PVB4022AS (only PVB000AS shown).

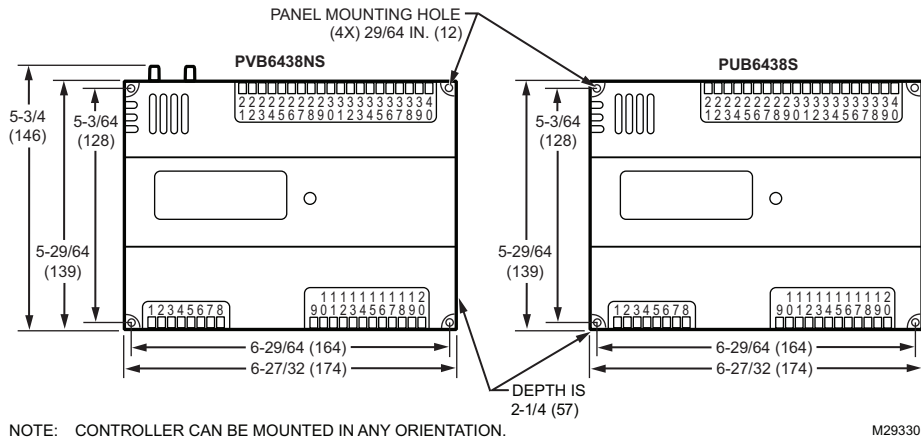

Fig. 7. Panel mounting - controller dimensions in inches (mm) for models PUB6438S and PVB6438NS.

Panel Mounting

The controller enclosure is constructed of a plastic base plate

and a plastic factory-snap-on cover.

NOTE: The controller is designed so that the cover does not need to be removed from the base plate for either mounting or wiring.

The controller mounts using four screws inserted through the corners of the base plate. Fasten securely with four No. 6 or No. 8 machine or sheet metal screws.

The controller can be mounted in any orientation. Ventilation openings are designed into the cover to allow proper heat dissipation, regardless of the mounting orientation.

DIN Rail Mounting (PUB1012S, PUB4024S, PUB6438S, PVB4024NS, and PVB6438NS.)

To mount the PUB1012S, PUB4024S, PUB6438S, PVB4024NS, or PVB6438NS controller on a DIN rail [standard EN50022; 1-3/8 in. x 9/32 in. (7.5 mm x 35 mm)], refer to Fig. 8 and perform the following steps:

1. Holding the controller with its top tilted in towards the DIN rail, hook the two top tabs on the back of the controller onto the top of the DIN rail.
2. Push down and in to snap the two bottom flex connectors of the controller onto the DIN rail.

IMPORTANT

To remove the controller from the DIN rail, perform the following:

1. Push straight up from the bottom to release the top tabs.
2. Rotate the top of the controller out towards you and pull the controller down and away from the DIN rail to release the bottom flex connectors.

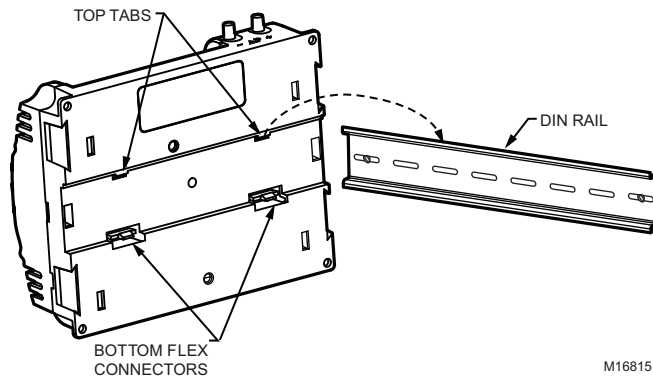

Fig. 8. Controller DIN rail mounting (PUB1012S, PUB4024S, PUB6438S, PVB4024NS, and PVB6438NS).

Piping (PVB0000AS, PVB4022AS, PVB4024NS, PVB6436AS, and PVB6438NS)

Air flow Pickup

For PVB0000AS, PVB4022AS, PVB4024NS, PVB6436AS, and PVB6438NS, connect the air flow pickup to the two restrictor ports on the controller (see Fig. 9).

NOTES:

- Use 1/4 inch (6 mm) outside diameter, with a 0.040 in. (1 mm) wall thickness, plenum-rated 1219 FR (94V-2) tubing.

- Always use a fresh cut on the end of the tubing that connects to the air flow pickups and the restrictor ports on the controller.

Connect the high pressure or upstream tube to the plastic restrictor port labeled (+), and the low pressure or downstream tube to the restrictor port labeled (-). See labeling in Fig. 9. When twin tubing is used from the pickup, split the pickup tubing a short length to accommodate the connections.

NOTES:

- If controllers are mounted in unusually dusty or dirty environments, an inline, 5-micron disposable air filter (use 5-micron filters compatible with pneumatic controls) is recommended for the high pressure line (marked as +) connected to the air flow pickup.
- The tubing from the air flow pickup to the controller should not exceed three feet (0.914 m). Any length greater than this will degrade the flow sensing accuracy.
- Use caution when removing tubing from a connector. Always pull straight away from the connector or use diagonal cutters to cut the edge of the tubing attached to the connector. Never remove by pulling at an angle.

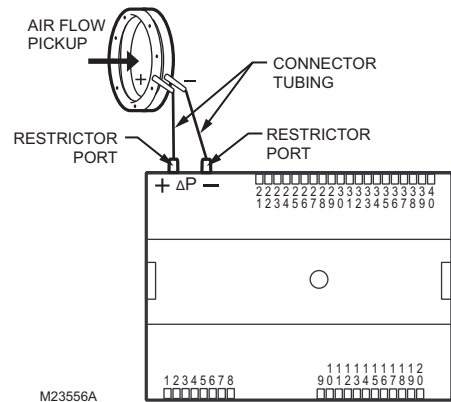

Fig. 9. Air flow pickup connections (PVB0000AS, PVB4022AS, PVB4024NS, PVB6436AS, and PVB6438NS).

Wiring

All wiring must comply with applicable electrical codes and ordinances, or as specified on installation wiring diagrams. Controller wiring is terminated to the screw terminal blocks located on the top and the bottom of the device.

⚠ WARNING

Electrical Shock Hazard.
Can cause severe injury, death or property damage.

Disconnect power supply before beginning wiring or making wiring connections, to prevent electrical shock or equipment damage.

NOTES:

- For multiple controllers operating from a single transformer, the same side of the transformer secondary must be connected to the same power input terminal in each controller. Controller

configurations will not necessarily be limited to three devices, but the total power draw, including accessories, cannot exceed 100 VA when powered by the same transformer (U.S. only). The earth ground terminal (terminal 3) must be connected to a verified earth ground for each controller in the group (see Fig. 11 on page 6).

- All loads on the controller must be powered by the same transformer that powers the controller itself. A controller can use separate transformers for controller power and output power.
- Keep the earth ground connection (terminal 3) wire run as short as possible.
- Do not connect the universal input COM terminals, analog output COM terminals or the digital input/output COM terminals to earth ground.

The 24 Vac power from an energy limited Class II power source must be provided to the controller. To conform to Class II restrictions (U.S. only), the transformer must not be larger than 100 VA.

Fig. 10 depicts a single controller using one transformer.

IMPORTANT

Power must be off prior to connecting to or removing connections from the 24 Vac power (24 Vac/24 Vac COM), earth ground (EGND), and 20 Vdc power (20 Vdc) terminals.

IMPORTANT

Use the heaviest gauge wire available, up to 14 AWG (2.0 sq mm), with a minimum of 18 AWG (1.0 sq mm), for all power and earth ground wiring.

Screw-type terminal blocks are designed to accept up to one 14 AWG (2.0 sq mm) conductor or up to two 18 AWG (1.0 sq mm) conductors. More than two wires that are 18 AWG (2.0 sq mm) can be connected with a wire nut. Include a pigtail with this wire group and attach the pigtail to the terminal block.

IMPORTANT

Connect terminal 2, (the 24 Vac common [24 VAC COM] terminal) to earth ground (see Fig. 10).

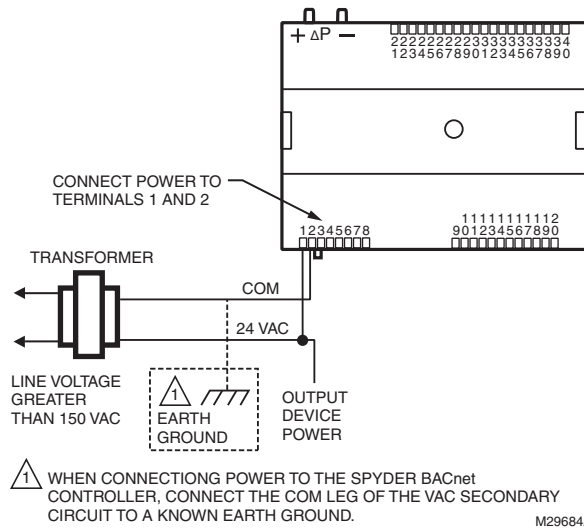

Fig. 10. Power wiring details for one controller per transformer.

More than one controller can be powered by a single transformer. Fig. 11 shows power wiring details for multiple controllers.

NOTE: Controller configurations are not necessarily limited to three devices, but the total power draw, including accessories, cannot exceed 100 VA when powered by the same transformer (U.S. only).

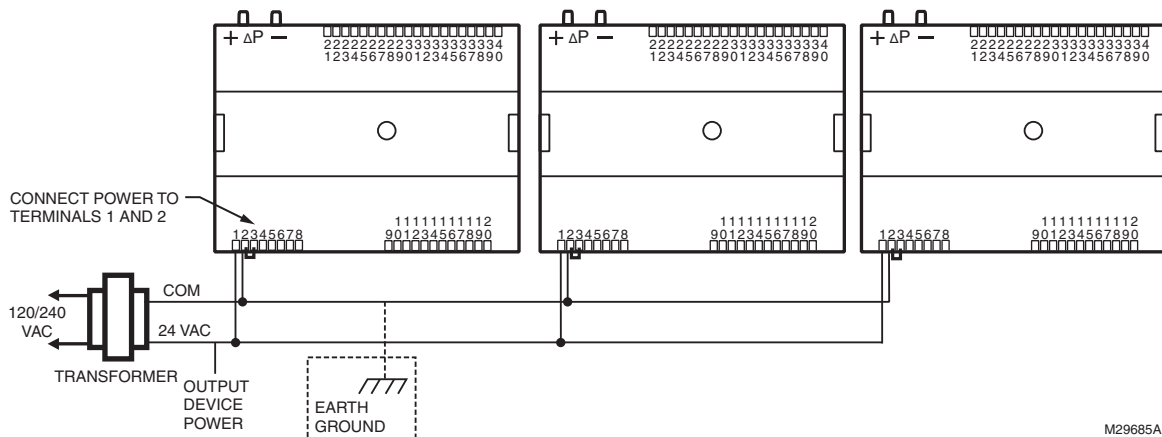

Fig. 11. Power wiring details for two or more controllers per transformer.

Communications

Each controller uses a BACnet MS/TP communications port. The controller's data is presented to other controllers over a twisted-pair MS/TP network, which uses the EIA-485 signaling standard capable of the following baud rates: 9.6, 19.2, 38.4,

76.8 or 115.2 Kilobits per second (configured at global controller). The Spyder BACnet controllers are master devices on the MS/TP network. Each Spyder BACnet controller uses a high-quality EIA-485 transceiver and exerts 1/4 unit load on the MS/TP network.

Cabling should be selected that meets or exceeds the BACnet Standard which specifies the following: An MS/TP EIA-485 network shall use shielded, twisted-pair cable with characteristic impedance between 100 and 130 ohms. Distributed capacitance between conductors shall be less than 100 pF per meter (30 pF per foot). Distributed capacitance between conductors and shield shall be less than 200 pF per meter (60 pF per foot). Foil or braided shields are acceptable. The Honeywell tested and recommended MS/TP cable is Honeywell Cable 3322 (18 AWG, 1-Pair, Shielded, Plenum cable), alternatively Honeywell Cable 3251 (22 AWG, 1-Pair, Shielded, Plenum cable) is available and meets the BACnet Standard requirements (www.honeywellcable.com).

The maximum BACnet MS/TP network Bus segment length is 4,000 ft. (1,071 m) using recommended wire. Repeaters must be used when making runs longer than 4,000 ft. (1,071 m). A maximum of three repeaters can be used between any two devices.

Setting the MS/TP MAC address

The MS/TP MAC address for each device must be set to a unique value in the range of 0-127 on an MS/TP network segment (address 0, 1, 2, & 3 should be avoided as they are commonly used for the router, diagnostic tools, and as spare addresses). DIP switches on the Spyder BACnet controller are used to set the controller's MAC address.

To set the MS/TP MAC address of a Spyder BACnet controller:

1. Find an unused MAC address on the MS/TP network to which the Spyder BACnet controller connects.
2. Locate the DIP switch bank on the Spyder BACnet for addressing. This is labeled MAC Address
3. With the Spyder BACnet Controller powered down, set the DIP switches for the MAC Address you want. Add the value of DIP switches set to ON to determine the MAC address. See Table 2. Example, if only DIP switches 1, 3, 5, and 7 are enabled the MAC address would be 85 (1 + 4 + 16 + 64 = 85).

Table 2. DIP Switch Values For MS/TP MAC Address.

DIP	7	6	5	4	3	2	1
VALUE	64	32	16	8	4	2	1

Setting the Device Instance Number

The Device Instance Number must be unique across the entire BACnet system network because it is used to uniquely identify the BACnet devices. It may be used to conveniently identify the BACnet device from other devices during

installation. The Spyder BACnet Controllers Device Instance Number is automatically set when it is added to a WEBStation-AX project. The Device Instance Number can be changed by the user, which may be necessary when integrating with a third party or when attempting to replace an existing controller and it is desired to maintain the existing Device Instance Number.

To edit the Device Instance Number using WEBs AX:

1. Identify an unused Device Instance Number on the BACnet Network, in the range of 0 - 4194302.
2. Open the Spyder Bacnet Device Mgr View
 - a. Double click on the BacnetNetwork located in the Nav tree.
 - b. Select the Spyder Controller to be modified.
 - c. Click on the Edit button.
 - d. Enter an unused value in the Device Id field.
 - e. Select OK
3. Right Click on the Spyder Controller and select Actions > Write Device Instance to complete the update

Termination Resistors

Matched terminating resistors are required at each end of a segment bus wired across (+) and (-). Use matched precision resistors rated 1/4W ±1% / 80 - 130 Ohms. Ideally, the value of the terminating resistors should match the rated characteristic impedance of the installed cable. For example, if the installed MS/TP cable has a listed characteristic impedance of 120 Ohm, install 120 Ohm matched precision resistors.

Shield Terminating

Following proper MS/TP cabling shield grounding procedures is important to minimize the risk of communication problems and equipment damage caused by capacitive coupling. Capacitive coupling is caused by placing MS/TP cabling close to lines carrying higher voltage. The shield should be grounded on only one end of the MS/TP segment (typically the router end). Tie the shield through using the SHLD (terminal 4) on the Spyder BACnet Controller.

Sylk™ Bus

Sylk is a two wire, polarity insensitive bus that provides both 18 VDC power and communications between a Sylk-enabled sensor and a Sylk-enabled controller. Using Sylk-enabled sensors saves I/O on the controller and is faster and cheaper to install since only two wires are needed and the bus is polarity insensitive. Sylk sensors are configured using the latest release of the Spyder Tool for WEBPro and WEBStation.

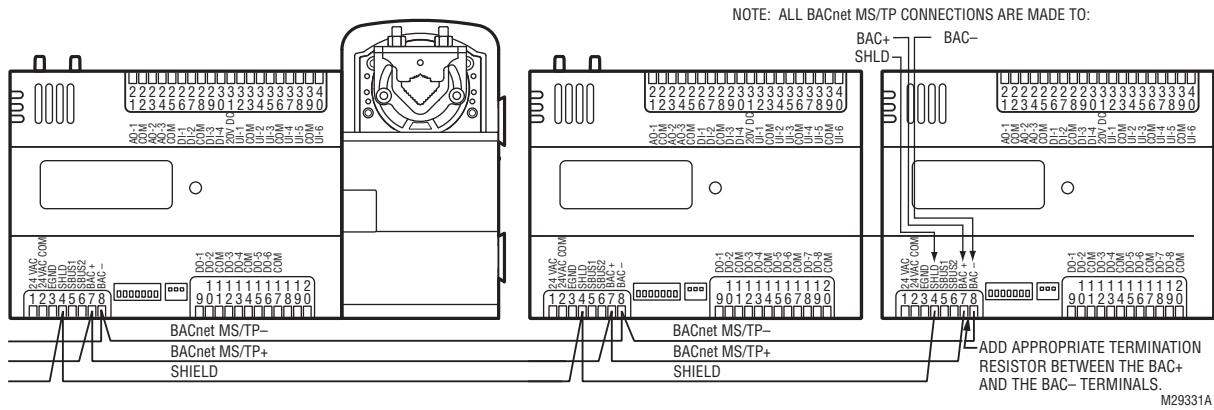

Fig. 12. Termination modules.

Wiring Method

⚠ WARNING

Electrical Shock Hazard.
Can cause severe injury, death or property damage.

Disconnect power supply before beginning wiring, or making wiring connections, to prevent electrical shock or equipment damage.

NOTE: When attaching two or more wires to the same terminal, other than 14 AWG (2.0 sq mm), be sure to twist them together. Deviation from this rule can result in improper electrical contact (see Fig. 13).

Each terminal can accommodate the following gauges of wire:

- Single wire: from 22 AWG to 14 AWG solid or stranded
- Multiple wires: up to two 18 AWG stranded, with 1/4 watt wire-wound resistor

Prepare wiring for the terminal blocks, as follows:

1. Strip 1/2 in. (13 mm) insulation from the conductor.
2. Cut a single wire to 3/16 in. (5 mm). Insert the wire in the required terminal location and tighten the screw.
3. If two or more wires are being inserted into one terminal location, twist the wires together a minimum of three turns before inserting them (see Fig. 13).
4. Cut the twisted end of the wires to 3/16 in. (5 mm) before inserting them into the terminal and tightening the screw.
5. Pull on each wire in all terminals to check for good mechanical connection.

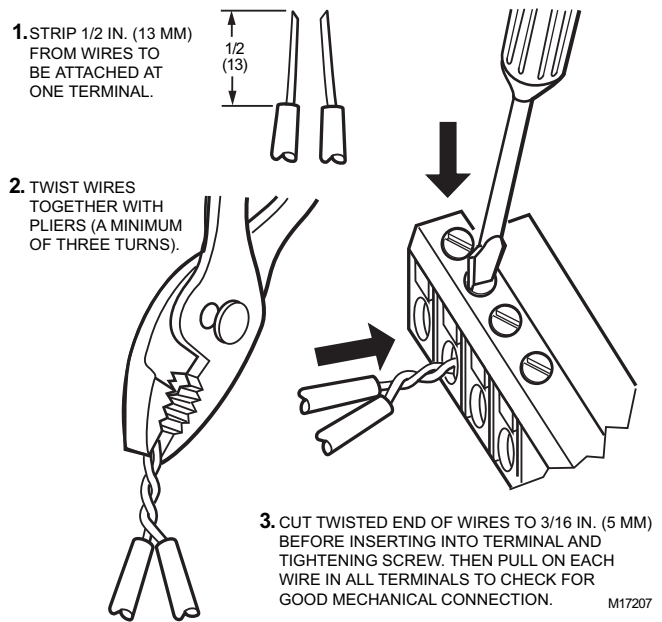

Fig. 13. Attaching two or more wires at terminal blocks.

Controller Replacement (PVB0000AS, PVB4022AS, and PVB6436AS)

For PVB0000AS, PVB4022AS, and PVB6436AS controllers, which are hard-wired to an actuator, perform the following actions to replace the complete assembly (controller and actuator):

1. Remove all power from the controller.
2. Remove the two air flow pickup connections from the pressure sensor.
3. Remove the terminal blocks.
4. Remove the old controller and actuator assembly from its mounting.
 - Loosen the two bolts on the actuator clamp to release the actuator from the shaft.
 - Remove the controller's mounting screws.
 - Gently pull the controller and actuator assembly straight out, until the assembly is clear of the actuator shaft.

5. Mount the new controller and actuator assembly (See “Installation” on page 2.).
6. Reconnect the two air flow pickup tubes to the pressure sensor (See “Piping (PVB0000AS, PVB4022AS, PVB4024NS, PVB6436AS, and PVB6438NS)” on page 4).
7. Replace the terminal blocks:
 - Insert each terminal block onto its alignment pins.
 - Press straight down to firmly seat it.
 - Repeat for each terminal block.
8. Restore power to the controller.

Controller Replacement (PVB4024NS and PVB6438NS)

Perform the following to replace the PVB4024NS and PVB6438NS controllers:

1. Remove all power from the controller.
2. Remove the two air flow pickup connections from the pressure sensor.
3. Remove the terminal blocks.
4. Remove the old controller from its mounting.

IMPORTANT

(FOR CONTROLLERS MOUNTED TO A DIN RAIL):

1. Push straight up from the bottom to release the top pins.
 2. Rotate the top of the controller outwards to release the bottom flex connectors (see Fig. 8 on page 5).
5. Mount the new controller.
 - See “Installation” on page 2.

6. Reconnect the two air flow pickup tubes to the pressure sensor (See “Piping (PVB0000AS, PVB4022AS, PVB4024NS, PVB6436AS, and PVB6438NS)” on page 4).
7. Replace the terminal blocks:
 - Insert each terminal block onto its alignment pins.
 - Press straight down to firmly seat it.
 - Repeat for each terminal block.
8. Restore power to the controller.

Controller Replacement (PUB1012S, PUB4024S, and PUB6438S)

Perform the following to replace the PUB1012S, PUB4024S, and PUB6438S controllers:

1. Remove all power from the controller.
2. Remove the terminal blocks.
3. Remove the old controller from its mounting.

IMPORTANT

(FOR CONTROLLERS MOUNTED TO A DIN RAIL):

1. Push straight up from the bottom to release the top pins.
 2. Rotate the top of the controller outwards to release the bottom flex connectors (see Fig. 8 on page 5).
4. Mount the new controller (See “Installation” on page 2.).
 5. Replace the terminal blocks:
 - Insert each terminal block onto its alignment pins.
 - Press straight down to firmly seat it.
 - Repeat for each terminal block.
 6. Restore power to the controller.

By using this Honeywell literature, you agree that Honeywell will have no liability for any damages arising out of your use or modification to, the literature. You will defend and indemnify Honeywell, its affiliates and subsidiaries, from and against any liability, cost, or damages, including attorneys' fees, arising out of, or resulting from, any modification to the literature by you.

Automation and Control Solutions

Honeywell International Inc.
1985 Douglas Drive North
Golden Valley, MN 55422
customer.honeywell.com

© U.S. Registered Trademark
© 2014 Honeywell International Inc.
62-0310—05 M.S. Rev. 01-14
Printed in United States

Honeywell