

600 Series

Electric Demand Drains

Models: EDD 601-04, EDD 602-04, EDD 603-04, EDD 604-04

FORM NO.: 7428306 REVISION: 09/2013

READ AND UNDERSTAND THIS MANUAL PRIOR TO OPERATING OR SERVICING THIS PRODUCT.

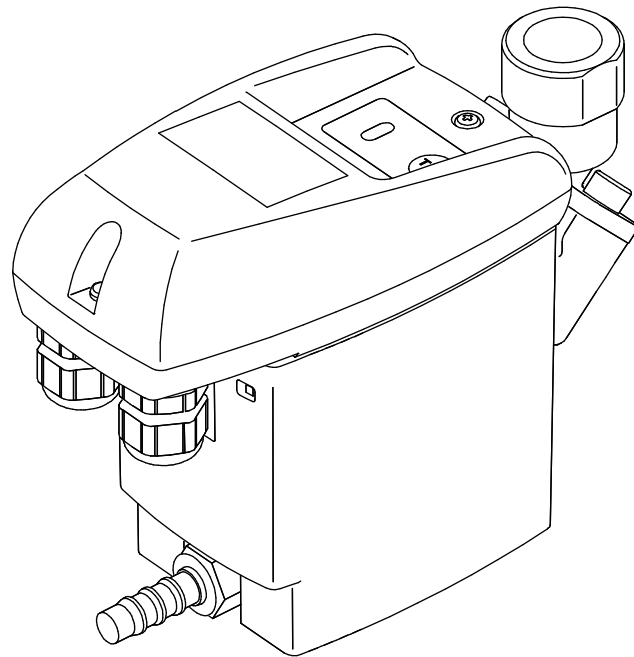

CONTENTS

GENERAL INFORMATION.....	1
1.0 FUNCTION	1
2.0 INSTALLATION	2
3.0 MAINTENANCE.....	6
4.0 TROUBLESHOOTING GUIDE.....	7
5.0 ENGINEERING DATA	8
6.0 DIMENSIONS	8
7.0 COMPONENTS	9
WARRANTY	

GENERAL INFORMATION

- Do not exceed max. operating pressure (see type plate).
NOTE: Maintenance work must only be carried out when the device is not under pressure.
- Only use pressure-proof installation material.
The feed line (1/2") must be firmly fixed. Discharge line: short pressure hose to pressure-proof pipe. Please ensure that condensate cannot squirt onto persons or objects.
- In case conical connectors are used on the inlet side, avoid excessive tightening of the connectors.
- For locking or holding in position during installation, use spanner area at inflow point.
- The electrical installation must be carried out in compliance with the valid regulations.

NOTE: Maintenance work is only allowed when the device is in a de-energized condition. Electrical work must always be performed by a qualified electrician.

- Do not operate the device when there is a danger of frost.
- The Series 600 condensate drain will only function when voltage is being applied to the device.
- Do not use the test button for continuous draining.
- Do not use the Series 600 condensate drain in hazardous areas (with potentially explosive atmospheres).
- Only employ original spare parts, otherwise the guarantee will no longer be valid.

1.0 FUNCTION

The condensate flows through the feed line (1) into the Series 600 condensate drain and accumulates in the housing (2). A capacitive sensor (3) continuously registers the liquid level. As soon as the container is filled, a fixed waiting period begins during which more condensate accumulates. After the waiting time has expired the pilot valve (4) is then activated and the diaphragm (5) opens the outlet line (6) for discharging the condensate.

When the Series 600 condensate drain has been emptied, the outlet line is closed again quickly and tightly without wasting compressed air.

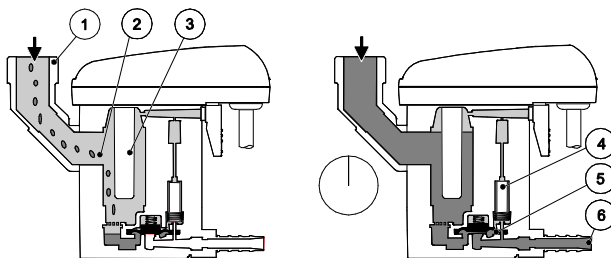

Ready for operation / Power on

The operating states of the Series 600 condensate drain are indicated by two LEDs.

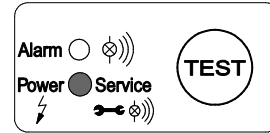

Malfunction / Alarm

If the condensate discharge is not functioning properly, an alarm mode starts which is indicated by the flashing of the red alarm LED.

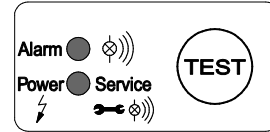

Test function

- Test of valve function and manual drainage: briefly press button.
- Test the alarm function (see below): press button for at least one (1) minute.

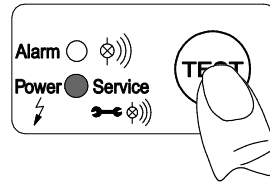

Switching sequence of valve in alarm mode

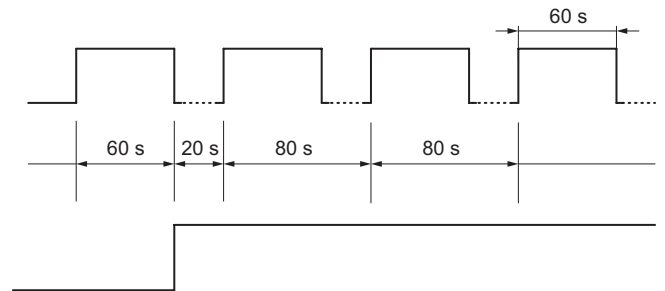

Alarm signal via potential-free contact.

Alarm-mode function:

If normal conditions have not been restored after 1 minute, a fault signal will be triggered:

- Alarm LED flashes.
- Alarm signal switches over (can be transmitted via potential-free contact).
- Valve opens every 80 seconds for a period of 60 seconds.

Once the fault is cleared, the Series 600 condensate drain will automatically switch back to the normal mode of operation.

Malfunctioning could be caused by, e.g.:

- Mistakes during installation
- Dropping below the necessary minimum pressure
- Excessive condensate quantities (over-loading)
- Blocked/shut off outlet line
- Extreme amount of dirt particles
- Frozen piping

2.0 INSTALLATION

Only the displayed installation position of the Series 600 condensate drain valve is permissible. Never install in a horizontal or any other tilted position.

- Feed pipe (1) and ball valve (2) at least 1/2"
- No filter or screen in feed line
- Slope in feed line >1%
- Only use ball valves (2)
- Operating pressure:
Models 601 & 603 min. 18 psig max. 230 psig
Models 602 & 604 min. 12 psig max. 230 psig
- Short pressure hose (4) fixed on a pressure resistant pipe
- For each meter of rising slope in the outlet line (5), the required minimum pressure will increase by 1.5 psig.
- The rise of the outlet line (5) must not exceed 17 feet
- Lay collecting line (7) 3/4" with 1% of slope.
- Lead discharge pipe (6) from the top into collecting line (7).
- Prior to the start-up, always carry out a leak test and verify the correct engagement of the control unit.

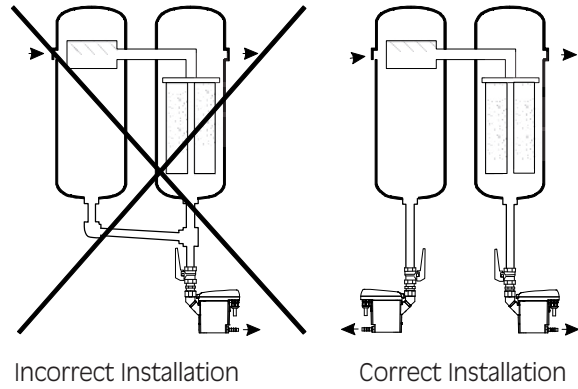
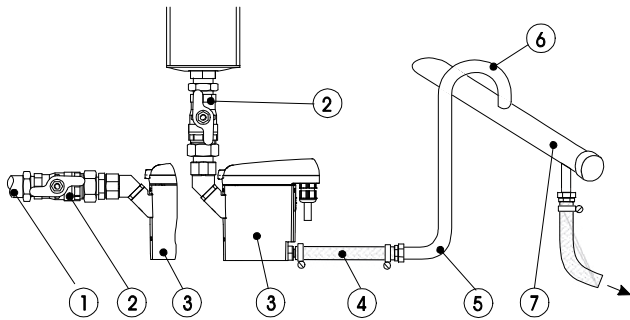

NOTE: Pressure Differences
Each condensate source must be drained separately.

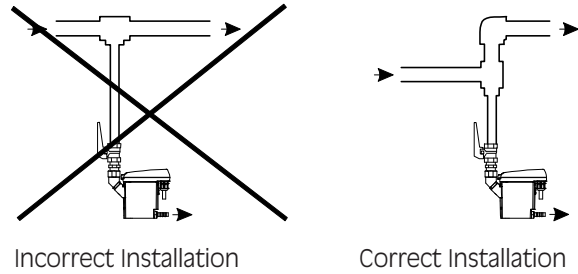

NOTE: Deflector Area
If drainage is to take place directly from a line, it is advisable to arrange the piping so that the air flow is diverted.

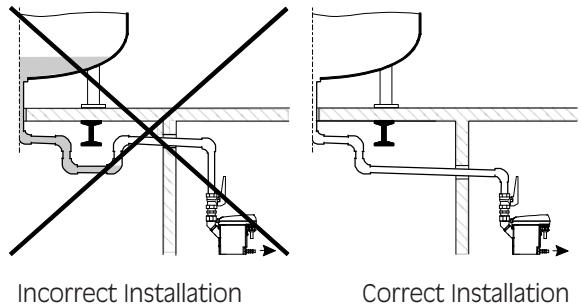

NOTE: Continuous Slope
Water pockets must be avoided when laying feed line.

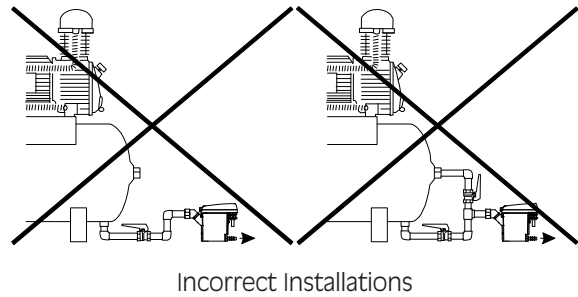

NOTE: No Venting Line
Do not install a vent line for a Series 600 condensate drain. Installations, where a venting line is normally required, are impossible in this case. Use another suitable drain valve.

2.1 Electrical Installation

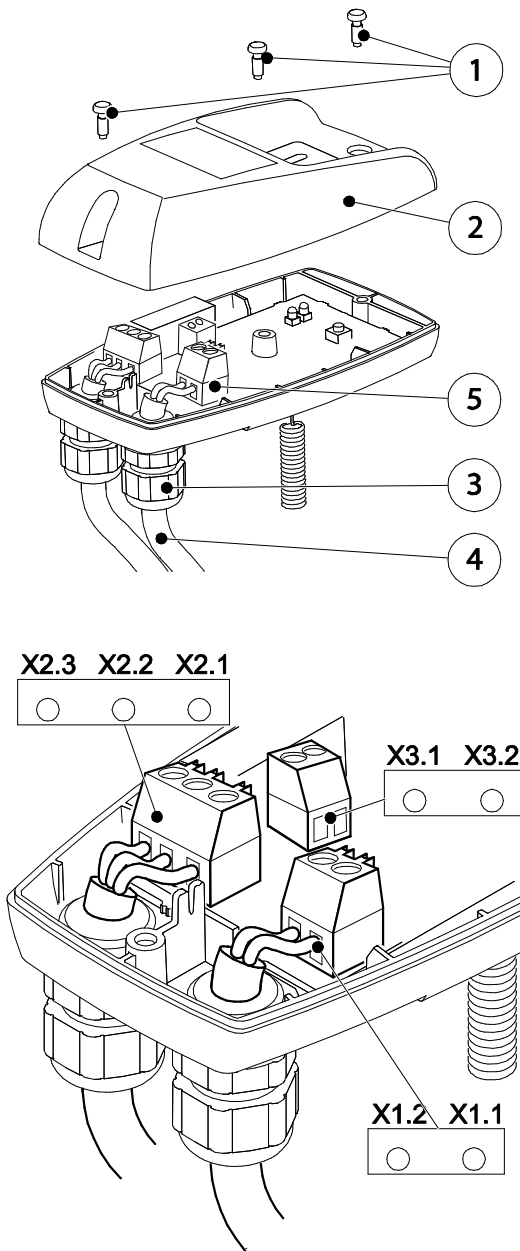

Notes before wiring:

1. The mains voltage must correspond to the permissible voltage on the type plate.
2. For the supply voltage, a reliably accessible separator must be provided close-by (e.g. power plug or switch), which separates all current-carrying conductors.
3. At a low-voltage supply (< 50 VAC / < 75 VDC), only use a protective extra-low-low voltage (PELV).
4. Please ensure that the installation is carried out according to the valid regulations.
5. Observe the terminal assignments.
6. DO NOT install when the device is energized.
7. Remove screws (1) and remove the upper part of the cover (2).
8. Unscrew the threaded cable connection (3), remove the plug (if there is one), and guide the cable (4) for the power supply through.
9. Connect the cable (4) with terminals X1 (1.1, 1.2) (5).
10. Install the cables as shown (see also terminal assignment in the following text).
11. Tighten the threaded cable connection (3) with a slightly sealing effect.
12. Re-install the upper part of the cover (2) and tighten the screws (1) finger tight.

Terminal assignment supply voltage (operating voltage)

X1		X2			X3	
1	2	1	2	3	1	2
phase	neutral	normally open	common	normally closed	external test (IN1)	GND
1.1	1.2	2.1	2.2	2.3	3.1	3.2

- X 1.1 L mains connection
- X 1.2 N mains connection

L = Outer conductor
N = Neutral conductor

Terminal assignment low voltage (operating voltage)

X1		X2			X3	
1	2	1	2	3	1	2
power	power	normally open	common	normally closed	external test (IN1)	GND
1.1	1.2	2.1	2.2	2.3	3.1	3.2

- X 1.1 Power Supply
- X 1.2 Power Supply

Connection of the potential-free contact and of the external test:

1. Selection of the suitable cable.
2. Connect to X2 and X3 as shown.
3. Installation steps are the same as for the power supply connection.
4. If the potential-free contact carries voltage that is dangerous in the case of contact, a corresponding separator must also be provided, as described above.
5. When using the potential-free contacts and the external test connection, ensure sufficient clearance to the other parts of the unit, or suitable insulation in accordance with valid regulations.
6. When using a multiwire, common line for the connection of the potential-free contact and the external test, this line must be suitable for the highest occurring voltage and the intended temperature range with regard to its nominal ratings. (e.g. nominal range ≥ 300 V and service temperature $\leq 1^\circ\text{C}$ and $\geq 60^\circ\text{C}$).

Terminal assignment of the potential-free contact of the external test

X1		X2			X3	
1	2	1	2	3	1	2
power	power	normally open	common	normally closed	external test (IN1)	GND
1.1	1.2	2.1	2.2	2.3	3.1	3.2

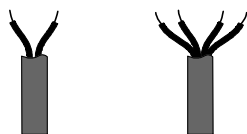

Alarm / potential-free contact

- X 2.1 N.O.
- X 2.2 COM.
- X 2.3 N.C.

N.C. - COM.

Contact closed during malfunction or power failure (fail-safe principle).

N.O. - COM.

Contact closed during normal operation.

The contacts X 2.1 - 2.3 are potential free.

External test / remote control

- X 3.1 external test (IN1)
- X 3.2 GND

Contacts connected = test active = discharge

Contact open = test inactive

The contacts X 3.1 - 3.2 are **NOT** potential free.

NOTE: For a low-voltage supply (< 50 VAC / < 75 VDC), only use a protective extra-low -voltage (PELV).

Tighten the threaded cable connection with a slight sealing effect.

2.2 Electrical Data

Supply voltage (see type plate)	24...48VAC $\pm 10\%$ (50...60Hz) / 18...72VDC $\pm 10\%$ or 95...240VAC $\pm 10\%$ (50...60Hz) / 100...125VDC $\pm 10\%$
Power consumption	P = 0.6 ... 3 VA (W)
Recommended cable-jack diameter	\varnothing 5.0... 10 mm (0.20"... 0.39")
Recommended wire cross-section Spring loaded terminal (voltage supply/ relay)	0.75...1.5 mm ² (AWG 16...20)
Recommended wire cross-section Screw terminal (voltage supply)	0.75...2.5 mm ² (AWG 14...20)
Recommended wire cross-section Spring loaded terminal (external test)	0.75...1.0 mm ² (AWG 18...20)
Recommended wire cross-section Screw terminal (relay/external test)	0.75...1.5 mm ² (AWG 16...20)
Connection data of the potential free contact Switch to load *)	AC: max. 250V / 1A DC: max. 30V / 1A
Connection data of the potential free contact Switch to low signal *)	min. 5 VDC / 10mA
Connection data of the external test contact	on the unit side 5 VDC; switching current ≥ 0.5 mA
Protection class	IP 67
Overvoltage category	II

VAC = V alternating current

VDC = V direct current

*) The switching of loads means that the properties of the contact are no longer suitable for the switching of low signals.

2.3 Electrical Diagram

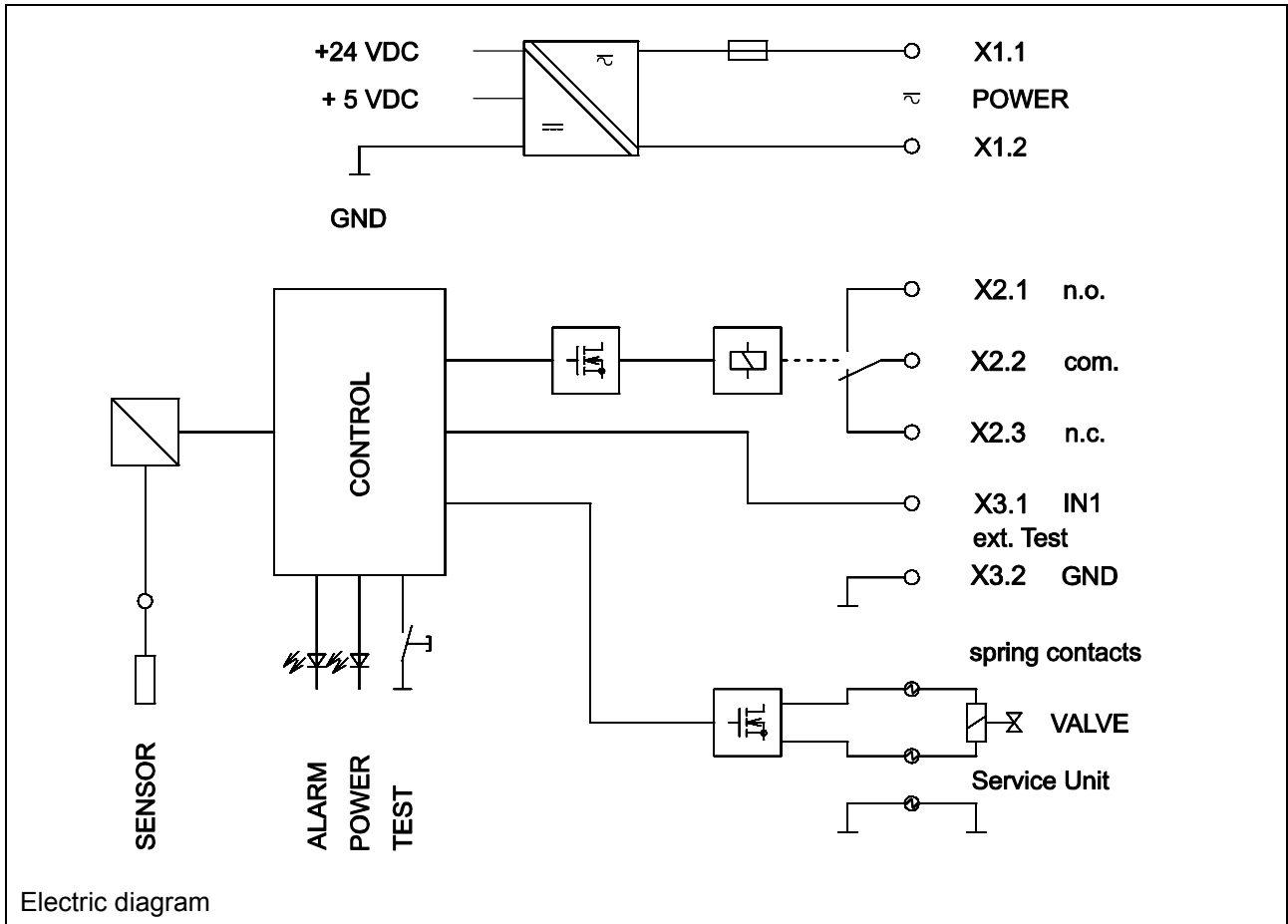

3.0 MAINTENANCE

Before maintenance work always ensure that the device is:

- pressureless and
- de-energized

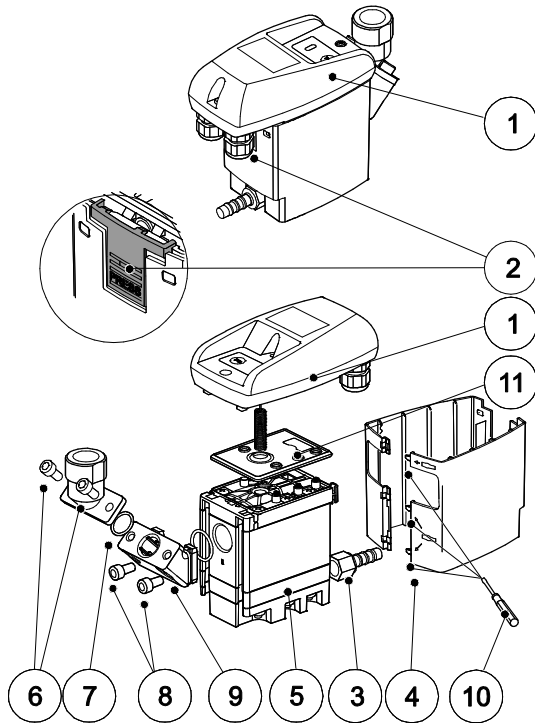

Maintenance recommendation:

1. After 8,760 operating hours or one million switching cycles, a maintenance message is released.

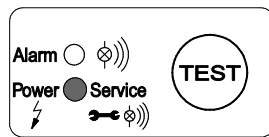

The green power LED flashes. Afterwards, or at the latest after one year (8,760 operating hours), replace the service unit (5).

2. Prior to replacement of the service unit, a reset needs to be carried out. The control unit is released by actuating the arresting hook. When removed, the TEST button below the LED must be pressed for at least five seconds.

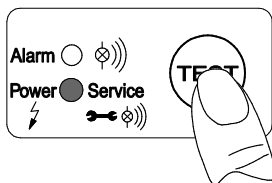

3. Remove the control unit (1) by pressing the arresting hook (2).
4. Unfasten from the outlet (3).
5. Remove the design shell (4) (if there is one) using a screwdriver (10).

6. Detach the service unit (5) from the tubing at the inlet by removing the union nut,
OR
remove the screws (6) from the angle nozzle (7).
OR
remove the screws (8) at the intermediate adapter (9) and remove the latter from the service unit by pulling it downwards.
7. Check whether or not the new service unit (5) goes with the control unit (1).
8. Reassemble new service unit (5) in reverse order. Do not over tighten screws (8).

Installation of the control unit on the service unit:

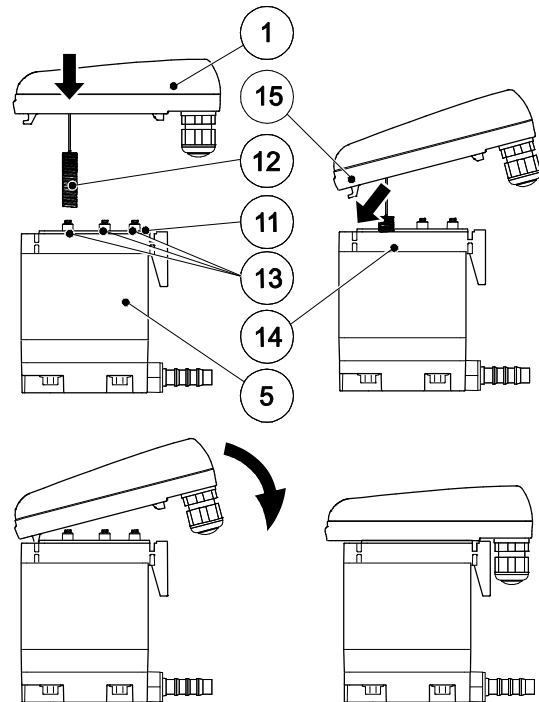

1. Check whether or not the service unit (5) goes with the control unit (1).
2. Check whether or not the sealing mat (11) and the contact springs (13) are clean, dry, and free from impurities.
3. Introduce the sensor (12) into the sensor tube plate (14).
4. Hang the hook (15) of the control unit (1) in the sensor tube plate (14).
5. Press the control unit (1) against the service unit (5) and snap into place.

Start-up subsequent to maintenance measures:

Always perform prior to the start-up:

1. Leak test of the screwed connector.
2. Check of the electrical connections.
3. Check of the correct engagement of the control unit.

4.0 TROUBLESHOOTING GUIDE

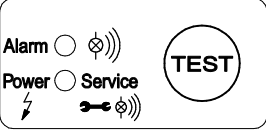
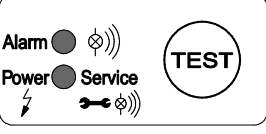
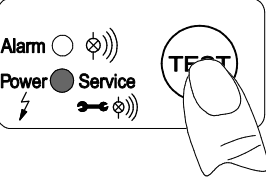
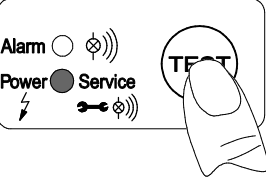
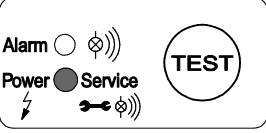
Symptom	Possible Causes	Corrective Action
<p>No LED lights up</p> 	<p>Power supply faulty Power supply board defective</p>	<p>Check voltage on the ID plate Check wiring (external and internal) Check plug connections Check the circuit boards for possible damage</p>
<p>All LEDs are continuously on</p> 	<p>Failure during the start of the programming Circuit board defective</p>	<p>Separate the device from the supply voltage. Restart after 5 seconds. Check the circuit boards for possible damage</p>
<p>Test button pressed, but no condensate discharge</p> 	<p>Feed and/or outlet line shut off or blocked Worn parts (seals, valve core, diaphragm) Control printed circuit board defective Service unit defective Minimum pressure not reached Maximum pressure exceeded</p>	<p>Check feed line and outlet line Replace worn parts Check if valve opens audibly (press test button several times) Check printed circuit boards for possible damage Check operating pressure</p>
<p>Condensate discharge only when the test button is pressed</p> 	<p>Feed line with insufficient slope; cross-section too small Excessive condensate quantities Service unit extremely dirty</p>	<p>Lay feed line with adequate slope Replace the service unit</p>
<p>Device keeps blowing off air</p> 	<p>Service unit defective or dirty</p>	<p>Replace the service unit</p>

5.0 ENGINEERING DATA

	Models 601 & 603	Models 602 & 604
Min. / Max. Operating Pressure (see type plate)	18 PSI / 230 psi	12 PSI / 230 psi
Min. / Max. Air Temperature (see type plate)	+34°F / +158°F	+34°F / +140°F
Condensate Inflow	1/2" NPT	1/2" BSP
Condensate Outflow	1/4" NPT with 3/8" Barbed Hose Connector	
Weight (empty)	2.2 lbs.	

6.0 DIMENSIONS

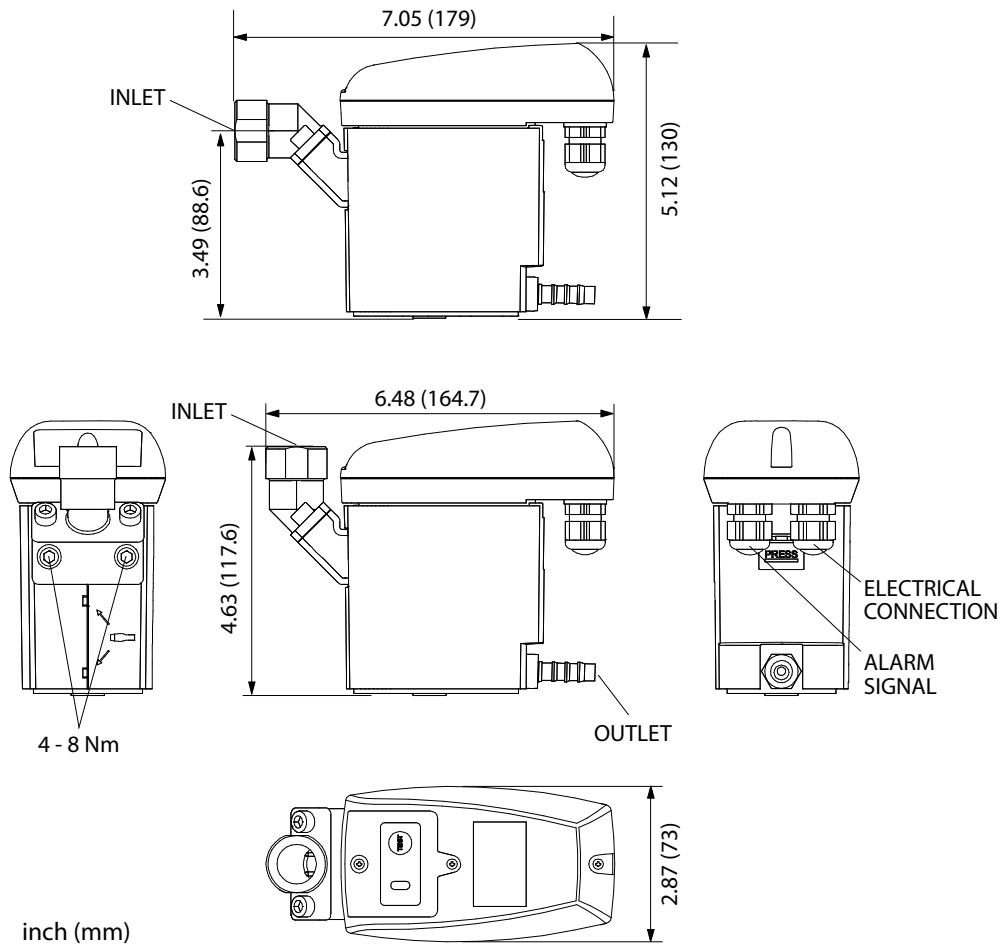

7.0 COMPONENTS

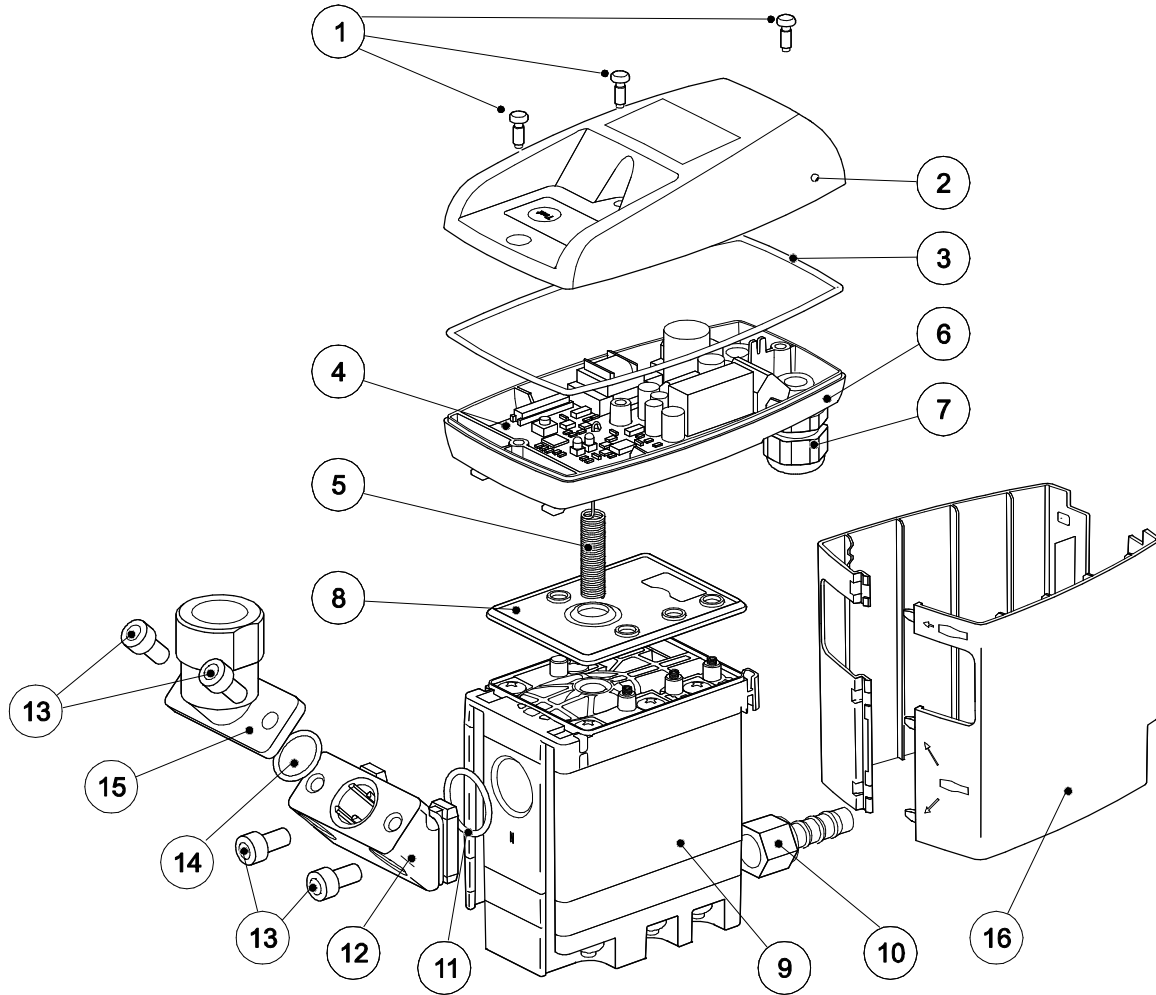

- | | |
|----------------------------|--|
| 1. Screw 3.5 x 10 | 9. Service unit |
| 2. Upper part of cover | 10. Hose connector Ø 1/4 |
| 3. Cord packing 2 x 352 | 11. O-ring 20 x 2 |
| 4. Circuit board | 12. Intermediate adapter |
| 5. Sensor | 13. Screw M6 x 12 |
| 6. Lower part of the cover | 14. O-ring 14 x 1.78 |
| 7. Cable bushing | 15. Angle adaptor G 1/2 |
| 8. Sealing mat | 16. Design shell (N/A: Models 603 & 604) |

WARRANTY

The manufacturer warrants the product manufactured by it, when properly installed, operated, applied, and maintained in accordance with procedures and recommendations outlined in manufacturer's instruction manuals, to be free from defects in material or workmanship for a period of one (1) year from the date of shipment to the buyer by the manufacturer or manufacturer's authorized distributor, or eighteen months from the date of shipment from the factory, whichever occurs first, provided such defect is discovered and brought to the manufacturer's attention within the aforesaid warranty period. The manufacturer will repair or replace any product or part determined to be defective by the manufacturer within the warranty period, provided such defect occurred in normal service and not as a result of misuse, abuse, neglect or accident.

The warranty covers parts and labor for the warranty period. Repair or replacement shall be made at the factory or the installation site, at the sole option of the manufacturer. Any service performed on the product by anyone other than the manufacturer must first be authorized by the manufacturer. Normal maintenance items requiring routine replacement are not warranted. Unauthorized service voids the warranty and any resulting charge or subsequent claim will not be paid. Products repaired or replaced under warranty shall be warranted for the unexpired portion of the warranty applying to the original product. The foregoing is the exclusive remedy of any buyer of the manufacturer's product. The maximum damages liability of the manufacturer is the original purchase price of the product or part.

THE FOREGOING WARRANTY IS EXCLUSIVE AND IN LIEU OF ALL OTHER WARRANTIES, WHETHER WRITTEN, ORAL, OR STATUTORY, **AND IS EXPRESSED IN LIEU OF THE IMPLIED WARRANTY OF MERCHANTABILITY AND THE IMPLIED WARRANTY OF FITNESS FOR A PARTICULAR PURPOSE.** THE MANUFACTURER SHALL NOT BE LIABLE FOR LOSS OR DAMAGE BY REASON OF STRICT LIABILITY IN TORT OR ITS NEGLIGENCE IN WHATEVER MANNER INCLUDING DESIGN, MANUFACTURE OR INSPECTION OF THE EQUIPMENT OR ITS FAILURE TO DISCOVER, REPORT, REPAIR, OR MODIFY LATENT DEFECTS INHERENT THEREIN. THE MANUFACTURER, HIS REPRESENTATIVE OR DISTRIBUTOR SHALL NOT BE LIABLE FOR LOSS OF USE OF THE PRODUCT OR OTHER INCIDENTAL OR CONSEQUENTIAL COSTS, EXPENSES, OR DAMAGES INCURRED BY THE BUYER, WHETHER ARISING FROM BREACH OF WARRANTY, NEGLIGENCE OR STRICT LIABILITY IN TORT.

The manufacturer does not warrant any product, part, material, component, or accessory manufactured by others and sold or supplied in connection with the sale of manufacturer's products.

AUTHORIZATION FROM THE SERVICE DEPARTMENT IS NECESSARY BEFORE MATERIAL IS RETURNED TO THE FACTORY OR IN-WARRANTY REPAIRS ARE MADE.

SERVICE DEPARTMENT: (724) 746-1100

600 Series

Electric Demand Drains

Models: EDD 601-04, EDD 602-04,
EDD 603-04, EDD 604-04



SPX

1000 Philadelphia Street
Canonsburg, PA 15317-1700 U.S.A.
P: (724) 745-1555
F: (724) 745-6040
E: hankison.americas@spx.com

www.hankisonintl.com

Improvements and research are continuous at SPX.
Specifications may change without notice.

ISSUED 09/2013 Form No.: 7428306 Revision: None
COPYRIGHT ©2013 SPX Corporation