

Features

- Unique sealing member isolates pilot air pressure from mainline fluid
- Variations in pilot air pressure do not affect valve operation
- Design provides long life handling of lubricated air
- Handle fluids up to 200°F (92°C)
- Some constructions handle steam up to 353°F (177°C)
- Mountable in any position

Construction

Valve Parts in Contact with Fluids		
Body	Brass	Stainless Steel
Seat	NBR or PTFE (for steam service)	

Air Operators

Connection Size: 1/8" NPT.

Actuated Displacement Volume: 0.60 cu. ins. for 3-30 psi operators;
 0.25 cu. ins. for 30-125 psi operator.

Media: Air

(For vacuum or other media, consult your local ASCO sales office for details. Refer to Optional Features Section for other available manual operators.)

Important

On 3-way and 4-way valves, except for those with zero minimum operating pressure, a Minimum Operating Pressure Differential must be maintained between the pressure and exhaust ports. Supply and exhaust piping must be full area, unrestricted. ASCO flow controls and similar components must be installed in the cylinder lines only.

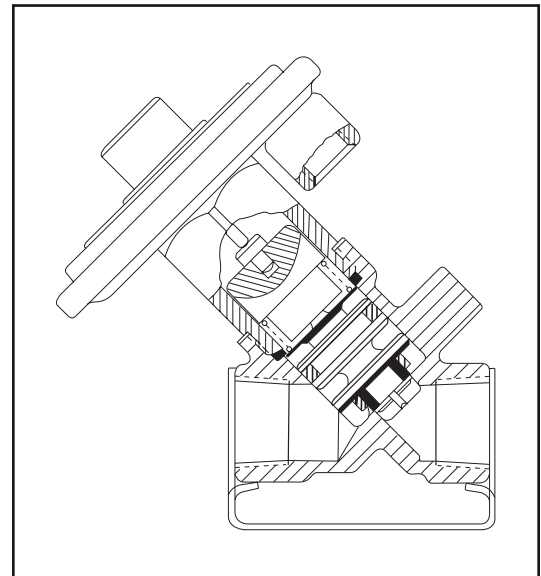

SPECIAL SERVICE VALVES

Nominal Ambient Temp. Ranges

32°F to 125°F (0°C to 52°C)

Refer to Engineering Section for details.

Ordering Information

We must have catalog number, operating pressure, and fluid to be handled. Use strainers with air operated valves.

Refer to Engineering Section for details.

Specifications (English units)

Pipe Size (ins.)	Orifice Size (ins.)	Cv Flow Factor	Main Line Operating Pressure (psi)					Max. Fluid Temp. °F	Instrument Air Operator 3-30 psi Range ①		Pneumatic Operator 30-125 psi Range ①		
			Min.	Maximum			Catalog Number		Const. Ref.	Catalog Number	Const. Ref.		
				Air-Inert Gas	Water	Lt. Oil @ 300 SSU						Steam	
2/2 VALVES													
NORMALLY CLOSED (Closed when operator exhausted), Brass Body with NBR Seating													
1/4	5/32	.50	0	125	125	125	-	200	F262B202K	1	P262B202	1	
1/4	9/32	.96	0	40	40	40	-	200	F262C090K	1	P262C090 ②	1	
3/8	5/8	2.8	0	125	125	125	-	180	F210C093K	6	P210C093	6	
3/8	3/8	1.5	1 ⑥	125	125	125	-	200	F210C073K	3	P210C073	3	
1/2	7/16	2.2	1 ⑥	125	125	125	-	200	F210A015K	4	P210A015	4	
1/2	5/8	3.6	0	125	125	125	-	180	F210C094K	6	P210C094	6	
3/4	3/4	5.5	0	125	125	125	-	180	F210D095K	7	P210D095	7	
3/4	3/4	5.5	5	125	125	125	-	180	F210D009K	8	P210D009	8	
1	1	13	5	125	125	125	-	180	F210D004K	10	P210D004	10	
1 1/4	1 1/8	15	5	125	125	125	-	180	F210D008K	12	P210D008	12	
1 1/2	1 1/4	22.5	5	125	125	125	-	180	F210D022K	14	P210D022	14	
2	1 3/4	43	5	125	125	125	-	180	F210 100K	15	P210 100	15	
NORMALLY OPEN (Open when operator exhausted), Brass Body with NBR Seating													
1/4	5/32	.50	0	125	125	125	-	200	F262B106K	2	P262B106	2	
3/8	5/8	2.8	0	125	125	125	-	180	F210C033K	16	P210C033	16	
1/2	5/8	3.5	0	125	125	125	-	180	F210C034K	16	P210C034	16	
3/4	3/4	5.5	0	125	125	125	-	180	F210C035K	17	P210C035	17	
1	1	13	5	125	125	125	-	180	F210D014K	18	P210D014	18	
NORMALLY CLOSED (Closed when operator exhausted), Stainless Steel Body with NBR Seating													
1/4	5/32	.50	0	125	125	125	-	200	F262B220K	22	-	-	
NORMALLY CLOSED (Closed when operator exhausted), Brass Body with PTFE Seating													
1/4	3/8	1.2	1	-	-	-	125	353	F222A070K	4	P222A070	4	
3/8	3/8	2.5	1	-	-	-	125	353	F222A074K	4	P222A074	4	
1/2	3/8	2.5	1	-	-	-	125	353	F222A076K	4	P222A076	4	
3/2 VALVES													
NORMALLY CLOSED (Closed when operator exhausted), Brass Body with NBR Seats													
1/4	9/32	③	10	125	125	125	-	200	F321A001K	5	P321A001	5	
3/8	9/32	③	10	125	125	125	-	200	F321A002K	5	P321A002	5	
3/8	5/8	3	10	125	125	-	-	200	F316D014K	2	P316D014	2	
1/2	5/8	4	10	125	125	-	-	200	F316D024K	2	P316D024	2	
3/4	11/16	5.5	10	125	125	-	-	200	F316E044K	3	P316E044	3	
1	1	13	10	125	125	-	-	200	F316E034K	4	P316E034	4	
UNIVERSAL (Pressure at any port), Brass Body with NBR Seats													
1/4	1/8	.31	0	125	125	125	-	200	F320A009K	1	P320A009	1	
4/2 VALVES													
Pipe Size (ins.)	Orifice Size (ins.)	Cv Flow Factor		Main Line Operating Pressure (psi)					Max. Fluid Temp. °F	Instrument Air Operator 3-30 psi Range		Pneumatic Operator 30-125 psi Range	
		Press. to Cyl.	Exh. to Cyl.	Min.	Maximum			Catalog Number		Const. Ref.	Catalog Number	Const. Ref.	
					Air-Inert Gas	Water	Lt. Oil @ 300 SSU						
2-Position Brass Body with Soft Seating ④													
1/4	3/16	.70	.70	0	125	125	125	160	-	-	P442C001	1	
1/4	1/4	.80	1	10 ⑤	125	125	125	200	F444B000K	2	P444B000	2	
3/8	3/16	.70	.70	0	125	125	125	160	-	-	P442C003	1	
3/8	3/8	1.4	2.2	10 ⑤	125	125	125	200	F444C025K	3	P444C025	3	

① 3-40 psi (2 - 2.8 bar) and 50-125 psi (3.4 - 8.6 bar) range for steam valves only.
 ② Refers to operator minimum pressure: Catalog Number P262C090 requires 50 psi (3.4 bar) minimum pressure.
 ③ Cv pressure to cylinder = 0.8 (.7 Kv); Cv cylinder to exhaust = 1.2 (1.0 Kv).
 ④ Const. Ref. 1 has soft seating; Const. Ref. 2 and 3 have soft to metal seating.
 ⑤ 25 psi (1.7 bar) required on light oil service.
 ⑥ 5 psi (0.35 bar) required for air service.

SPECIAL SERVICE VALVES

Specifications (Metric units)

Pipe Size (ins.)	Orifice Size (mm)	Kv Flow Factor (m3/h)	Main Line Operating Pressure (bar)					Max. Fluid Temp. °C	Instrument Air Operator 0.2-2 bar Range ①		Pneumatic Operator 2-8.6 bar Range ①	
			Min.	Maximum					Catalog Number	Const. Ref.	Catalog Number	Const. Ref.
				Air-Inert Gas	Water	Lt. Oil @ 300 SSU	Steam					
2/2 VALVES												
NORMALLY CLOSED (Closed when operator exhausted), Brass Body with NBR Seating												
1/4	4	.43	0.0	9	9	9	-	93	F262B202K	1	P262B202	1
1/4	7	.82	0.0	3	3	3	-	93	F262C090K	1	P262C090 ②	1
3/8	16	2.40	0.0	9	9	9	-	82	F210C093K	6	P210C093	6
3/8	10	1.29	0.07 ③	9	9	9	-	93	F210C073K	3	P210C073	3
1/2	11	1.89	0.07 ③	9	9	9	-	93	F210A015K	4	P210A015	4
1/2	16	3.09	0.0	9	9	9	-	82	F210C094K	6	P210C094	6
3/4	19	4.71	0.0	9	9	9	-	82	F210D095K	7	P210D095	7
3/4	19	4.71	0.3	9	9	9	-	82	F210D009K	8	P210D009	8
1	25	11.14	0.3	9	9	9	-	82	F210D004K	10	P210D004	10
1 1/4	29	12.86	0.3	9	9	9	-	82	F210D008K	12	P210D008	12
1 1/2	32	19.29	0.3	9	9	9	-	82	F210D022K	14	P210D022	14
2	45	36.86	0.3	9	9	9	-	82	F210 100K	15	P210 100	15
NORMALLY OPEN (Open when operator exhausted), Brass Body with NBR Seating												
1/4	4	.43	0.0	9	9	9	-	93	F262B106K	2	P262B106	2
3/8	16	2.40	0.0	9	9	9	-	82	F210C033K	16	P210C033	16
1/2	16	3.00	0.0	9	9	9	-	82	F210C034K	16	P210C034	16
3/4	19	4.71	0.0	9	9	9	-	82	F210C035K	17	P210C035	17
1	25	11.14	0.3	9	9	9	-	82	F210D014K	18	P210D014	18
NORMALLY CLOSED (Closed when operator exhausted), Stainless Steel Body with NBR Seating												
1/4	4	.43	0.0	9	9	9	-	93	F262B220K	22	-	-
NORMALLY CLOSED (Closed when operator exhausted), Brass Body with PTFE Seating												
1/4	10	1.03	0.1	-	-	-	24	178	F222A70K	4	P222A70	4
3/8	10	2.14	0.1	-	-	-	24	178	F222A74K	4	P222A74	4
1/2	10	2.14	0.1	-	-	-	24	178	F222A76K	4	P222A76	4
3/2 VALVES												
NORMALLY CLOSED (Closed when operator exhausted), Brass Body with NBR Seats												
1/4	7	③	0.6895	9	9	9	-	93	F321A001K	5	P321A001	5
3/8	7	③	0.6895	9	9	9	-	93	F321A002K	5	P321A002	5
3/8	16	2.57	0.6895	9	9	-	-	93	F316D014K	2	P316D014	2
1/2	16	3.43	0.6895	9	9	-	-	93	F316D024K	2	P316D024	2
3/4	17	4.71	0.6895	9	9	-	-	93	F316E044K	3	P316E044	3
1	25	11.14	0.6895	9	9	-	-	93	F316E034K	4	P316E034	4
UNIVERSAL (Pressure at any port), Brass Body with NBR Seats												
1/4	3	.27	0	9	9	9	-	93	F320A009K	1	P320A009	1
4/2 VALVES												
Pipe Size (ins.)	Orifice Size (mm)	Kv Flow Factor (m3/h)		Main Line Operating Pressure (bar)				Max. Fluid Temp. °C	Instrument Air Operator 0.2-2 bar Range		Pneumatic Operator 2-8.6 bar Range	
		Press. to Cyl.	Exh. to Cyl.	Min.	Maximum				Catalog Number	Const. Ref.	Catalog Number	Const. Ref.
					Air-Inert Gas	Water	Lt. Oil @ 300 SSU					
2-Position Brass Body with Soft Seating ④												
1/4	5	.60	.60	0	9	9	9	71	-	-	P442C001	1
1/4	6	.69	.86	0.7 ⑤	9	9	9	93	F444B000K	2	P444B000	2
3/8	5	.60	.60	0	9	9	9	71	-	-	P442C003	1
3/8	10	1.20	1.89	0.7 ⑤	9	9	9	93	F444C025K	3	P444C025	3

① 3-40 psi (.2 - 2.8 bar) and 50-125 psi (3.4 - 8.6 bar) range for steam valves only.

② Refers to operator minimum pressure; Catalog Number P262C090 requires 50 psi (3.4 bar) minimum pressure.

③ Cv pressure to cylinder = 0.8 (.7 Kv); Cv cylinder to exhaust = 1.2 (1.0 Kv).

④ Const. Ref. 1 has soft seating; Const. Ref. 2 and 3 have soft to metal seating.

⑤ 25 psi (1.7 bar) required on light oil service.

⑥ 5 psi (0.35 bar) required for air service.

SPECIAL SERVICE VALVES

Dimensions inches (mm)

Const. Ref.		Instrument Air Operator 2/2 Valves with 3-30 PSI Operator ①				Pneumatic Operator 2/2 Valves with 30-125 PSI Operator ①			
		H	L	P	W	H	L	P	W ②
1	ins.	2.88	1.57	2.47	Ø 2.66	3.34	1.56	2.94	1.18
	mm	73	40	63	Ø 67	85	40	75	30
2	ins.	2.97	1.56	2.56	Ø 2.66	2.78	1.56	2.38	1.18
	mm	75	40	65	Ø 67	71	40	60	30
3	ins.	3.34	1.91	2.91	Ø 2.66	3.69	1.91	3.25	1.12
	mm	85	49	74	Ø 67	94	49	83	28
4	ins.	3.62	2.28	3.09	Ø 2.66	4.22	2.28	3.66	1.12
	mm	92	58	79	Ø 67	107	58	93	28
6	ins.	3.59	2.75	3.03	Ø 2.66	4.00	2.75	3.44	2.28
	mm	91	70	77	Ø 67	102	70	87	58
7	ins.	3.81	2.81	3.19	Ø 2.66	4.22	2.81	3.59	2.28
	mm	97	71	81	Ø 67	107	71	91	58
8	ins.	3.88	2.81	3.22	Ø 2.66	4.28	2.81	3.62	2.31
	mm	99	71	82	Ø 67	109	71	92	59
10	ins.	5.53	3.75	3.91	Ø 2.66	6.00	3.75	4.38	2.94
	mm	141	95	99	Ø 67	152	95	111	75
12	ins.	5.53	2.66	3.91	Ø 2.66	6.00	3.66	4.38	3.38
	mm	141	68	99	Ø 67	152	93	111	86
14	ins.	6.00	4.38	4.06	4.38	6.50	4.38	4.53	3.75
	mm	152	111	103	111	165	111	115	95
15	ins.	7.22	5.06	4.47	4.68	7.69	5.06	4.94	4.68
	mm	183	129	114	119	195	129	126	119
16	ins.	3.69	2.75	3.12	Ø 2.66	3.44	2.75	2.88	2.28
	mm	94	70	79	Ø 67	87	70	73	58
17	ins.	3.91	2.81	3.28	Ø 2.66	3.69	2.81	3.03	2.28
	mm	99	71	83	Ø 67	94	71	77	58
18	ins.	5.63	3.75	4.00	2.94	5.43	3.75	3.81	2.94
	mm	143	95	102	75	138	95	97	75
22	ins.	2.84	Ø1.62	2.47	Ø 2.66	X	X	X	X
	mm	72	Ø 41	63	Ø 67	X	X	X	X

① When barbed tubing adapter is used, add 1.19 ins. (30 mm) to "H" and/or "P" (or overall) dimensions.
② Represents overall width of valve.

2/2 Valves - Const. Ref. 1, 2

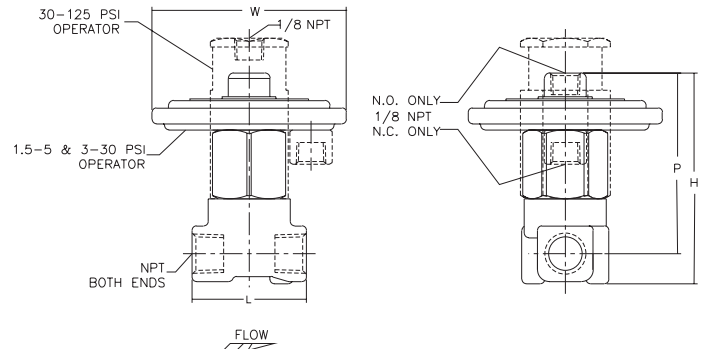

2/2 Valves - Const. Ref. 3, 4

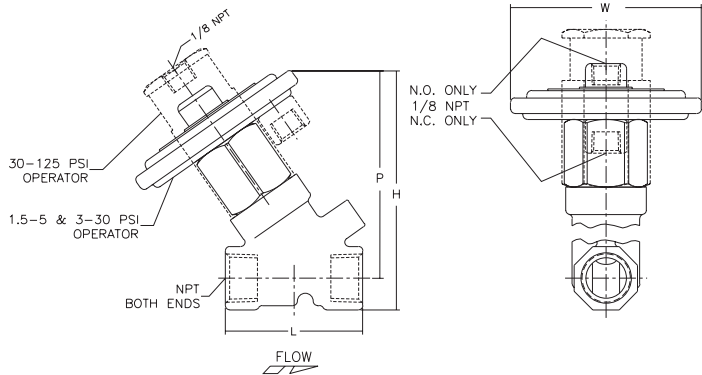

2/2 Valves - Const. Ref. 22

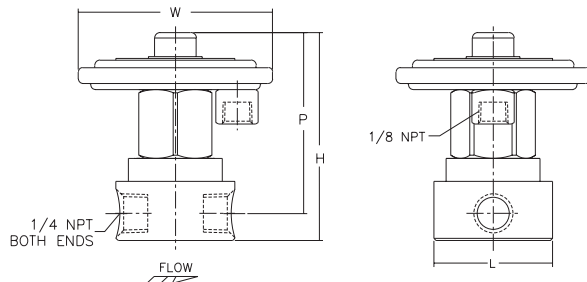

2/2 Valves - Const. Ref. 6 - 18

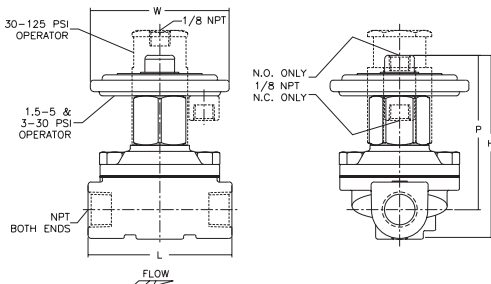

Mounting Bracket Const. Ref. 1, 2

MOUNTING HOLES
IN VALVE BODY
BRASS CONSTR. REFS. 1 & 2

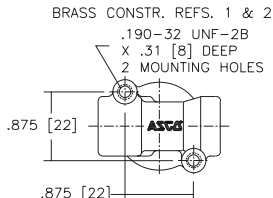

Mounting Bracket Const. Ref. 6 - 18

MOUNTING BRACKET
CONSTR. REF. 6, 7, 8, 9, 10,
11, 12, 13, 14-21

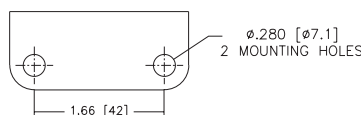

Mounting Bracket Const. Ref. 1, 2, 3, 4, 22

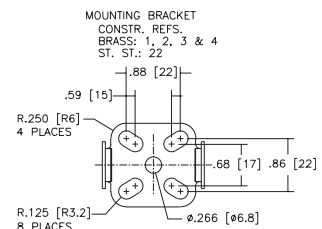

SPECIAL SERVICE VALVES

Dimensions inches (mm)

Const. Ref.	Instrument Air Operator 3/2 Valves with 3-30 psi Operator ①			Pneumatic Operator 3/2 Valves with 30-125 psi Operator ①							
		H	P	W ②	H	P	W ②	L	N	M	R
1	ins.	3.56	2.56	Ø 2.66	3.38	2.38	1.12	1.69	X	X	X
	mm	90	65	Ø 67	86	61	28	43	X	X	X
2	ins.	5.07	3.93	4.30	4.89	3.75	4.30	2.76	X	X	X
	mm	129	100	109	124	95	109	70	X	X	X
3	ins.	6.00	4.31	3.31	5.82	4.13	3.31	3.38	.53	2.16	.50
	mm	152	109	84	148	105	84	86	13	55	13
4	ins.	6.62	4.56	5.34	6.44	4.38	5.34	4.44	.88	2.68	.88
	mm	168	116	136	164	111	136	113	22	68	22
5	ins.	3.84	2.81	3.39	3.66	2.62	2.62	3.12	X	X	X
	mm	98	71	86	93	67	67	79	X	X	X

① When barbed tubing adapter is used, add 1.19 ins. (30 mm) to "H" and/or "P" (or overall) dimensions.

② Represents overall width of valve.

3/4 Valves Const. Ref. 1

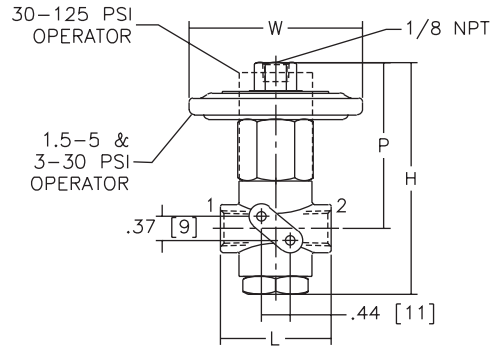

2 Mounting holes 0.28 (0.07 mm) deep for No. 8 thread cutting screw

3/4 Valves Const. Ref. 2

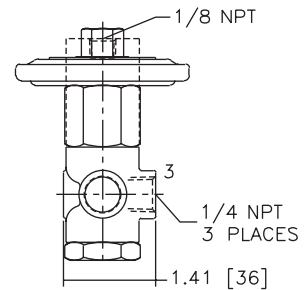
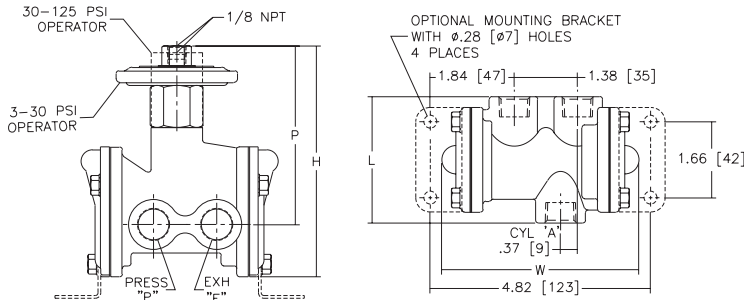

3/4 Valves Const. Ref. 3, 4

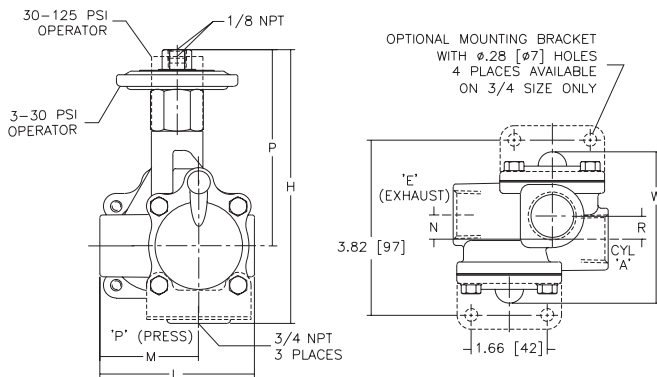

3/4 Valves Const. Ref. 5

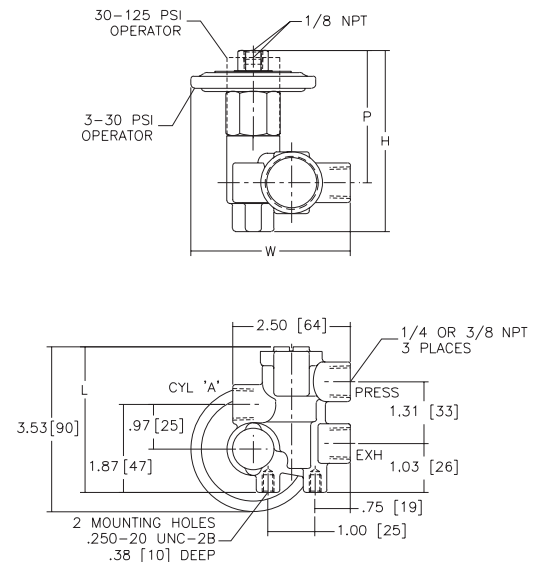

SPECIAL SERVICE VALVES

Dimensions inches (mm)

Const. Ref.	Instrument Air Operator 4/2 Valves with 3-30 psi (.2-2 bar) Operator ①			Pneumatic Operator 4/2 Valves with 30-125 psi (2-8.6 bar) Operator ①												
	H	P	W	H	P	W	E	F	J	L	N	X	Y	Z	DIA D	
2	ins.	3.91	2.94	4.75	3.72	2.75	4.75	.56	2.41	1.03	3.12	.72	1.41	1.56	.81	Ø .28
	mm	99	75	121	94	70	121	14	61	26	79	18	36	40	21	Ø 7
3	ins.	3.88	2.75	6.06	3.69	2.56	6.06	.75	3.12	1.50	3.19	.84	1.88	1.90	.84	Ø .34
	mm	98	70	154	94	65	154	19	79	38	81	21	48	48	21	Ø 9

① When barbed tubing adapter is used, add 1.19 (30 mm) to "H" and/or "P" (or overall) dimensions.
IMPORTANT: Valves can be mounted in any position.

4/2 Valves - Const. Ref. 1

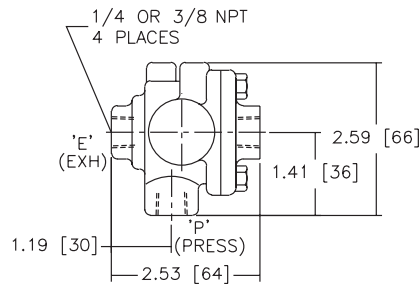
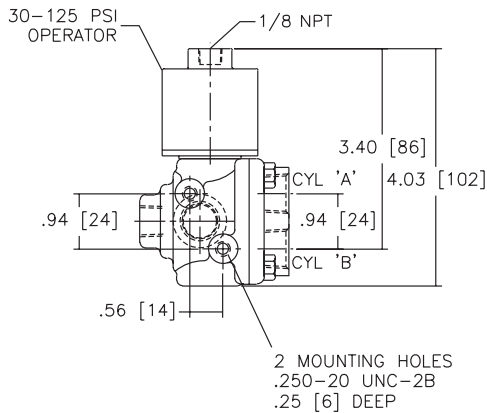

4/2 Valves - Const. Ref. 2, 3

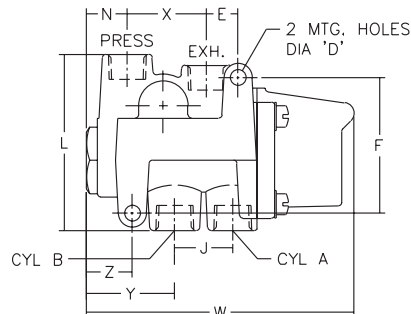
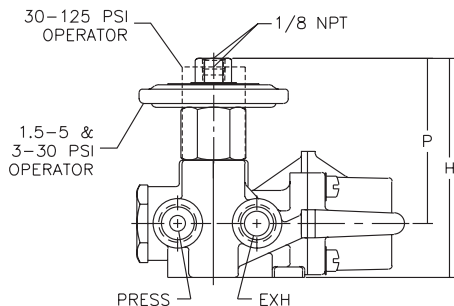

Flow Diagrams

Const. Ref. 1

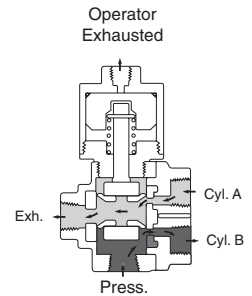

Operator Pressurized

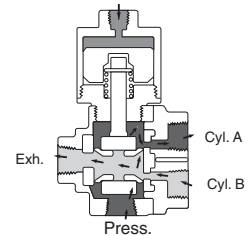

Const. Ref. 2, 3, 4

Operator Exhausted

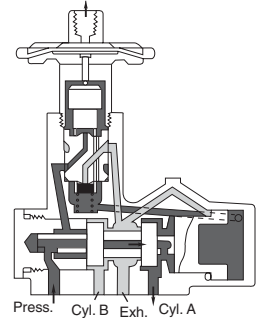

Operator Pressurized

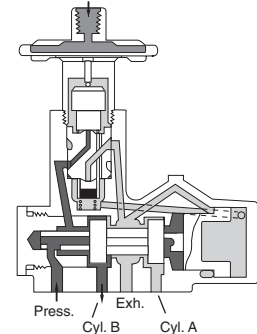

SPECIAL SERVICE VALVES