

Product Identification

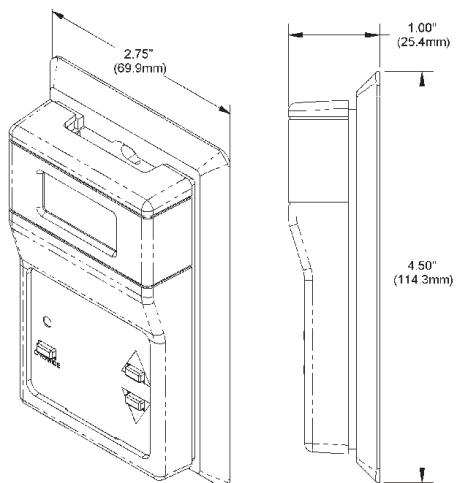
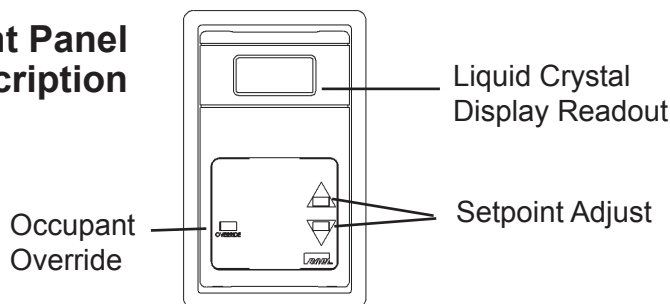

Fig 1: RuP Room Sensor

Front Panel Description



Setpoint

When the setpoint buttons are pressed “UP” or “DOWN”, the current setpoint will display. As the buttons are pressed again, the display will change with each press.

Override

For Override, momentarily press the Override button.

Mounting

Mounting hardware is provided for both junction box and drywall installation (junction box installation shown).

JUNCTION BOX

1. Pull wire through the wall and out of the junction box, leaving about 6 inches free.
2. Pull the wire through the hole in the base plate.
3. Secure the plate to the box using the #6-32 x 1/2” mounting screws provided.
4. Terminate the unit according to the **Termination Guidelines** section.
5. Attach Cover by latching it to the top of the base, rotating the cover down and snapping it into place.
6. Secure the cover by backing out the lock-down screws using a 1/16” allen wrench until they are flush with the bottom of the cover.

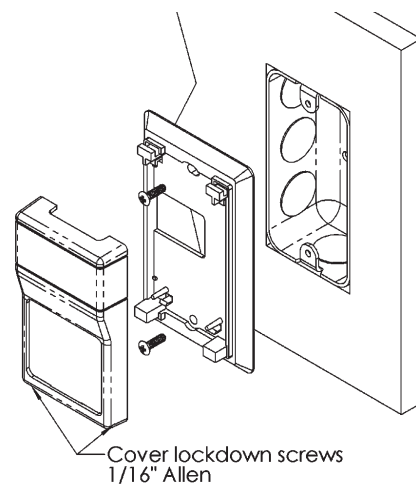

Fig 2: Junction box mounting

DRYWALL MOUNTING

1. Place the base plate against the wall where you want to mount the sensor.
2. Use a pencil to mark the two mounting holes and the area where the wires will come through the wall.
3. Drill two 3/16” holes in the center of each marked mounting hole. Insert a dry-wall anchor into each hole.
4. Drill one 1/2” hole in the middle of the marked wiring area.
5. Pull the wire through the wall and out of 1/2” hole, leaving about 6” free.
6. Pull the wire through the hole in the base plate.
7. Secure the base to the drywall anchors using the #6 x 1 inch mounting screws provided.
8. Terminate the unit according to the **Termination Guidelines** section.
9. Attach cover by latching it to the top of the base, rotating the cover down and snapping it into place. Secure the cover by backing out the lock-down screws using a 1/16” Allen wrench until they are flush with the bottom of the cover.

NOTE: In a wall-mount application, the wall temperature and the temperature of the air within the wall cavity can cause erroneous readings. The mixing of room air and air from within the wall cavity can lead to condensation, erroneous readings and premature failure of the sensor. To prevent these conditions, seal the conduit leading to the junction box and use BAPI’s adhesive backed, foam insulating pad centered over the hole (order part number BA/FOAMBACK).

Specifications subject to change without notice.

Termination

BAPI recommends using twisted pair of at least 22AWG and sealant filled connectors for all wire connections. Larger gauge wire may be required for long runs. All wiring must comply with the National Electric Code (NEC) and local codes. Do NOT run this device's wiring in the same conduit as AC power wiring of NEC class 1, NEC class 2, NEC class 3 or with wiring used to supply highly inductive loads such as motors, contactors and relays. BAPI's tests show that fluctuating and inaccurate signal levels are possible when AC power wiring is present in the same conduit as the signal lines. If you are experiencing any of these difficulties, please contact your BAPI representative



BAPI recommends wiring the product with power disconnected. Proper supply voltage, polarity, and wiring connections are important to a successful installation. Not observing these recommendations may damage the product and will void the warranty.

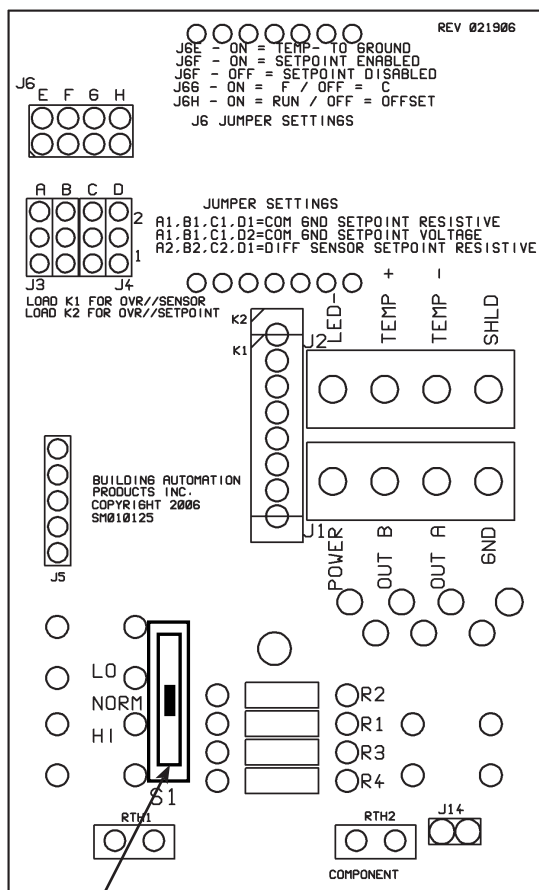

Fig 3: RuP Circuit Board

Shown with optional T&B Switch (S1)

ALL RUP UNITS

Terminal	Function
POWER	5 VDC (only if 5 VDC option is selected when ordered) 7 to 35 VDC (15 to 24 VDC recommended) 12 to 30 VAC (requires a separate pair of shielded wires)
GND	To Controller GND, GROUND or Common terminal
LED -	Lights Occupancy LED when shorted to ground. To Controller Digital Output
SHLD	External sensor cable shield (Not used in this configuration)

COMMON GROUND UNITS ONLY

Terminal	Function
OUT A	Setpoint (Resistive or Voltage Output). To Controller Analog Input
OUT B	Temperature Sensor Output (Resistive Output). To Controller Analog Input

DIFFERENTIAL GROUND UNITS ONLY

Terminal	Function
TEMP +	Temperature Sensor Output. To Controller Analog Input
TEMP -	Temperature Sensor Output. To Controller Analog Input
OUT A	Setpoint (Resistive Output). To Controller Analog Input
OUT B	Setpoint (Resistive Output). To Controller Analog Input

NOTES

For Common Ground (CG) units, the GND (Common) terminal is common between the POWER, OUT A, and OUT B.

For Differential Ground (DF) units, OUT A and OUT B are the Setpoint Outputs, and TEMP + and TEMP - are the Thermistor or RTD sensor outputs.

Factory Set J3, J4 & J6 Jumper Block Settings (for reference only)

Jumper Block J3 and J4 Settings -

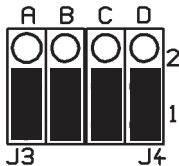

Fig 4:

Common Ground with Resistive Setpoint

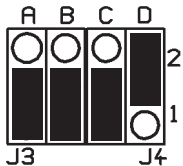

Fig 5:

Common Ground with 0 to 5VDC Setpoint

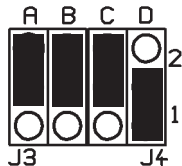

Fig 6:

Differential Ground with Resistive Setpoint

Jumper Block J6 Settings

Jumper Block J6 Settings (For Reference Only)		
Jumper Pin	Jumper	Function
J6E	ON	"TEMP -" to Ground
	OFF	Differential Ground
J6F	ON	Setpoint Enabled
	OFF	Setpoint Disabled
J6G	ON	Fahrenheit
	OFF	Celsius
J6H	ON	Normal Operation
	OFF	Offset Temperature - Use UP/DOWN arrows to set

Optional Communications Jack in Base

C35 Wiring	
	Wire Color
Ground	Black
Tip	White
Ring	Red

Note: Male Jack shown for clarity

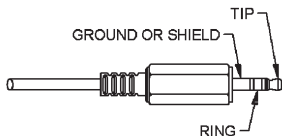
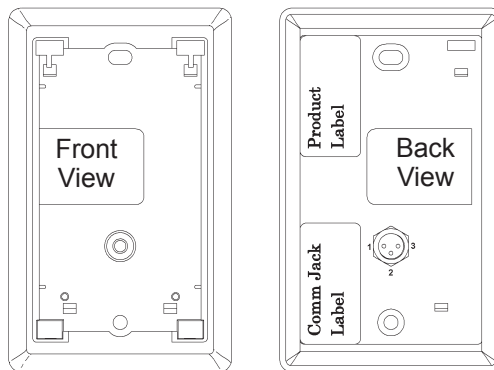

Fig. 7: C35 Comm Jack

Fig. 8: Front View of Base with C35 Comm Jack



C11 or C22 Wiring	
Comm Jack Pin	Wire Color
1	Not Connected
2	Black
3	Red
4	Yellow
5	White
6	Not Connected

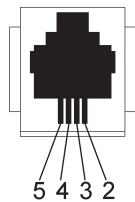
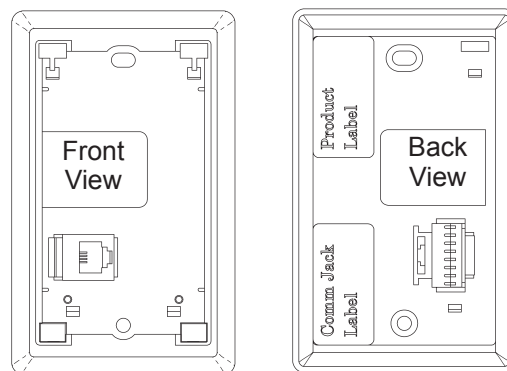

Fig. 10
C11 or C22 Comm Jack

Fig. 9: Front View of Base with C11 or C22 Comm Jack



Optional Test & Balance Switch - S1



LO: Sets the sensor value to LOW temperature

NORM: Temperature Sensor operates Normally

HI: Sets the sensor value to HIGH temperature

Sensor Type	Low Resistance (Temp)	High Resistance (Temp)
1000Ω RTD	1.02KΩ (41.2°F)	1.15KΩ (101.5°F)
3000Ω Thermistor	7.87KΩ (39.5°F)	1.5KΩ (106.8°F)
10K-2Ω Thermistor	30.1KΩ (34.9°F)	4.75KΩ (109.2°F)
10K-3Ω Thermistor	26.7KΩ (35.9°F)	5.11KΩ (108.4°F)
10K-3(11K)Ω Thermistor	7.32KΩ (43.7°F)	3.65KΩ (105.2°F)

Specifications subject to change without notice.



Temperature, Setpoint and Occupancy Override LED Diagnostics

If the RuP doesn't work upon installation, no LCD and no Output from terminals OUTA and/or OUTB. Check that the correct power is being supplied to the RuP by measuring the DC voltage between terminals POWER and GND. Also check to see that the RuP is wired with the proper polarity, terminal GND as common and terminal POWER as V+. V+ should be within the range of 7 to 35VDC, 12 to 30 VAC or optional 5 Volt and supply a minimum of 10mA for each RuP. If the RuP's LCD is working but there's still no output from terminal OUTA or OUTB. Power down the RuP and remove the output wire(s) from the suspect terminal pin(s). Apply power and use a meter to measure the ohms (or voltage) output of the terminal pin in question, as described in the three sections below.

TEMPERATURE OUTPUT

Determine that the temperature sensor's wires are connected to the correct controller input terminals and are not loose. Check the wires at the sensor and controller for proper connections. Measure the physical temperature at the temperature sensor's location using an accurate temperature standard. Disconnect the temperature sensor wire (SEN1) and measure the temperature sensor's resistance across the sensor output pins with an ohmmeter. Put the ohmmeter's black lead on Ground (GND) for common ground units or put the black lead on SEN2 for differential ground units and the red lead on SEN1. Compare the temperature sensor's resistance to the appropriate temperature sensor table on the BAPI web site. If the measured resistance is different from the temperature table by more than 5% call BAPI technical support. Find BAPI's web site at www.bapihvac.com; click on the button labeled SENSORS on the left of the screen and then click on the type of sensor you have. Don't forget to reconnect the wires. Make sure that the test and balance switch is in the correct position. Make sure that the temperature sensor element leads are not touching one another.

SETPOINT OUTPUT

The setpoint output may be measured on CG (common ground) units between terminals OUTA and GND. The setpoint output is measured on DF (differential input) units between terminal OUTA and OUTB. To test the setpoint output, first remove any wires from the setpoint output terminals, apply power to the RuP and measure the setpoint output. Compare the measured reading to the setpoint information printed on the RuP's label. The temperature setpoint value will be displayed on the RuP's LCD.

LED INDICATOR

The LED is internally connected to the RuP's 5 Volt supply and can be turned on by connecting the terminal LED- to the RuP's GND terminal. Most often this is done through a dry contact at the controller. To test the LED, first remove any wires from the LED- terminal, apply power to the RuP and then use a short piece of wire to short between the LED- and GND terminals. Observe the LED operation from the front of the RuP. Power down the RuP and reconnect the output(s) to the controller. If the output(s) still are non-functional, remove power and check the controller's input configuration.

Communications Jack Diagnostics

PROBLEMS:

No connection to controller can be made

POSSIBLE SOLUTIONS:

- Confirm connection from patch cable to remote computer
- Check wiring for proper termination

Information received through wires is garbled

- Check wiring for proper termination
- Verify that no wires are shorted together

Specifications

Power: 5 VDC (only if 5 VDC option is selected when ordered)
7 to 35 VDC (15 to 24 VDC recommended)
12 to 30 VAC (requires a separate pair of shielded wires)

Power Consumption: 10 mA max. DC, .2 VA maximum AC

Sensing Element: Thermistor, RTD or Semiconductor

Wiring: 2 to 4 pair of 16 to 22AWG*

Comm. Jack: Optional 3.5 mm Phono Jack, RJ11 or RJ22 Jacks

Mounting: Standard 2" by 4" J-box or drywall mount (mounting screws provided)

Environmental Operation Range:
Temperature: 32 to 122 °F (0 to 50 °C)
Humidity: 0 to 95%, non-condensing

Enclosure Material & Rating: ABS Plastic, UL94 HB

Specifications subject to change without notice.