

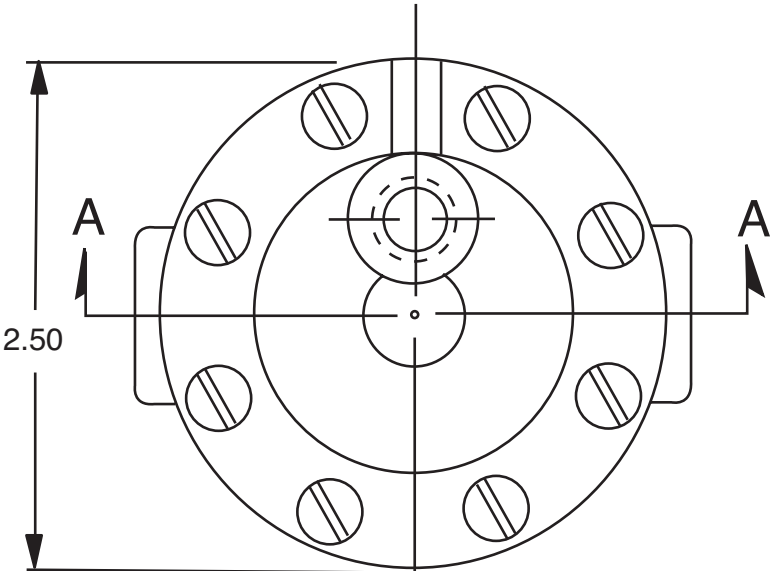

—MODEL—

100-01

# 3/8"-1 Hytrol Valve



### PARTS LIST

ITEM	DESCRIPTION
1.	Cover Screw (8 Required)
2.	Cover
3.	Spring
4.	Diaphragm Washer
* 5.	Diaphragm
* 6.	Disc Retainer Assembly
7.	Body Plug (3/8 NPT)
8.	Body

\* Recommended Spare Parts

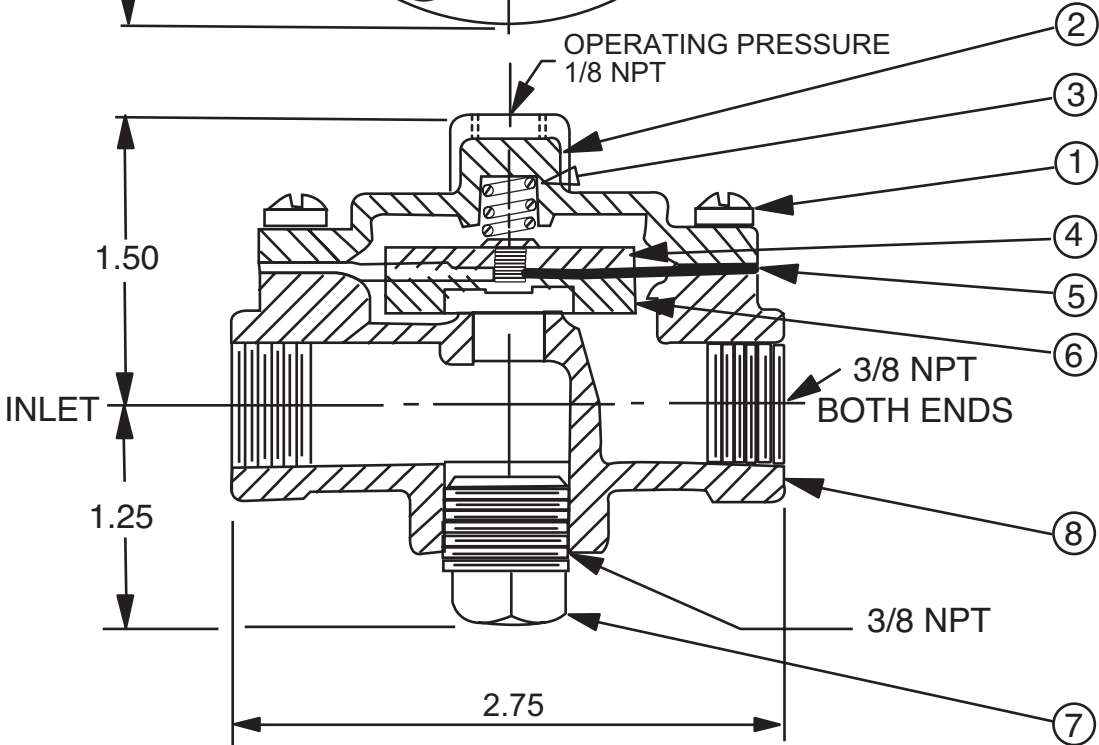

## SECTION AA

## 100-01 3/8" HYCTRL VALVE

**When Ordering parts, please specify**

- All nameplate data
- Description
- Item Number
- Material

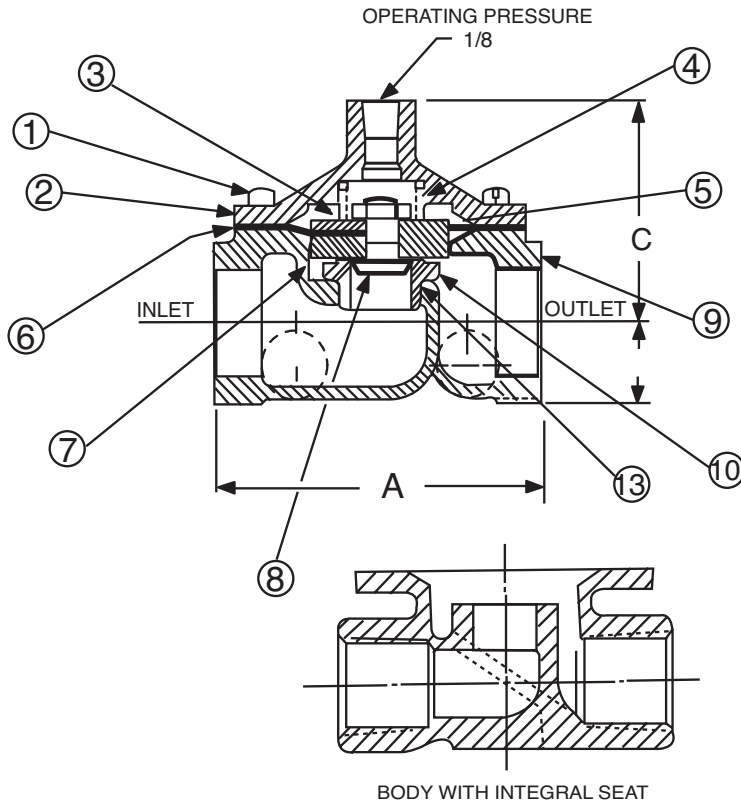
—MODEL— **100-01****1/2"-3/4"-1" Hytrol Valve****100-01 3/4" & 1/2" Hytrol Valve****PARTS LIST**

ITEM	DESCRIPTION
1	COVER SCREW
2	COVER
3	SPRING
4	STEM NUT
5	DIAPHRAGM WASHER
* 6	DIAPHRAGM
* 7	DISC RETAINER ASSEMBLY
8	DISC GUIDE & STEM
9	BODY
10	SEAT
11	NAMEPLATE
12	BODY PLUG HEX HD.
13	O-RING SEAT (FOR OLD STYLE BODY ONLY)

\* Recommended Spare Parts

	1/2	3/4
A	1-7/16	3-1/2
C (MAXIMUM)	2-3/8	2-3/8
D	25/32	29/32

**When Ordering parts, please specify**

- All nameplate data
- Description
- Item Number
- Material

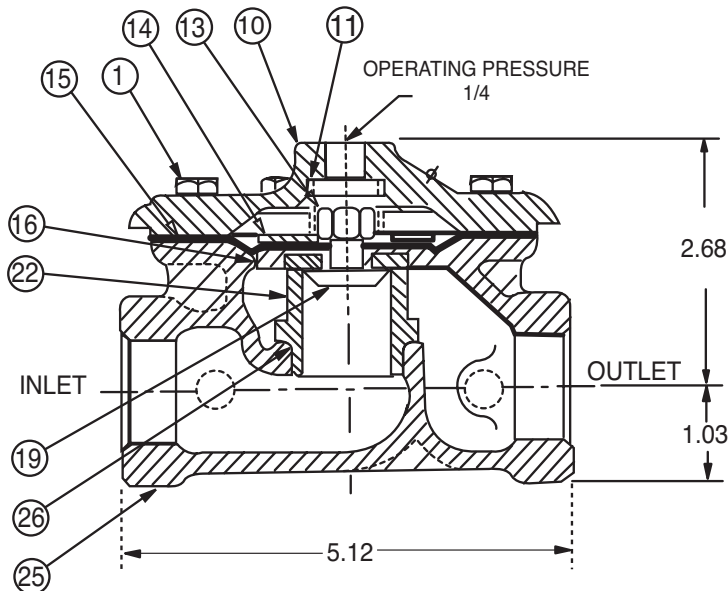
**100-01 1" Hytrol Valve****PARTS LIST**

ITEM	DESCRIPTION
1	COVER SCREW
2	NAMEPLATE
3	NAMEPLATE SCREW
10	COVER
11	SPRING
13	STEM NUT
14	DIAPHRAGM WASHER
15	DIAPHRAGM
16	DISC RETAINER ASSEMBLY
19	DISC GUIDE
22	SEAT
24	BODY PLUG
25	BODY
26	O-RING, SEAT

\* Recommended Spare Parts