

# HIGH EFFICIENCY COMMERCIAL CONDENSING BOILERS



**SMART SYSTEM**

OPERATING CONTROL FEATURING  
A BUILT-IN CASCADING SEQUENCER

5 MODELS: 399,000 – 800,000 BTU/HR

FIRING RATE MODULATION TO 5:1

LESS THAN 20 ppm NO<sub>x</sub>

DIRECT VENT FLEXIBILITY TO 100 FEET



**94%**  
**THERMAL EFFICIENCY**



[Lochinvar.com](http://Lochinvar.com)



## THE SMARTEST CHOICE FOR CONDENSING BOILER PERFORMANCE

The KNIGHT® XL, engineered with Lochinvar's exclusive SMART SYSTEM™ control and an array of other innovative features, places it far ahead of any commercial heating boiler in its class. It promises and delivers ultimate ease of installation and maintenance. With up to 94.6% thermal efficiency, low-NOx emissions and a fully modulating burner, it is the best "green choice" for today's environmentally focused market.

Five modulating/condensing stainless steel KNIGHT XL boilers are available with 399,000–800,000 Btu/hr inputs and remarkably small space-saving footprints. All are equipped for direct-vent installation with air intake and exhaust runs up to 100 feet using PVC, CPVC, Polypropylene or AL29-4C vent materials. This range of choices is ideal for light-duty applications such as small hotels, schools and office buildings. For higher-demand applications, up to eight KNIGHT XL units can be installed utilizing the built-in cascading sequencer to deliver up to 6.4 million Btu/hr heating capacity.

THE KNIGHT XL BOILER reflects Lochinvar's constant commitment to providing all the options you need to serve every application.



*KNIGHT XLs installed and commissioned by Black & M'Donald*

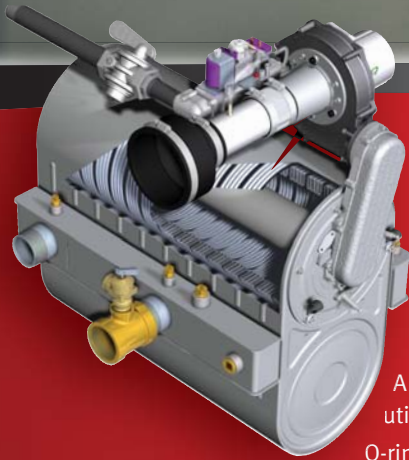

### ADVANCED NEGATIVE REGULATION TECHNOLOGY

KNIGHT XL safely and reliably operates with supply gas pressure as low as 4 inches water column. Negative Regulation (Neg/Reg) technology automatically adjusts fan speed that ensures the correct volume and mix of fuel and air throughout the firing range.

### TWO-IN-ONE STAINLESS STEEL HEAT EXCHANGER

A primary heat exchanger combined with a secondary heat exchanger captures flue gas heat and condenses to utilize available latent energy. The stainless steel, pH-tolerant design features a weld-sealed assembly with no O-rings or gaskets and does not require special glycol. ASME Section IV approved and stamped.

### FULLY MODULATING BURNER

The SMART SYSTEM allows fully modulating combustion with 5:1 turndown. The burner can fire as low as 20% of maximum input and modulates the firing rate up to 100% as demand increases. The burner is a single stainless steel assembly covered with woven steel mesh and fires in a 360° pattern along the entire length of the primary heat exchanger. This allows the compact KNIGHT XL to exceed the capacity of units with larger multiple burners.

### DIRECT VENTING UP TO 100 FEET



*SIDEWALL VENT TERMINATION*

KNIGHT XL offers 7 venting options and tremendous flexibility for placement of units within the building, because it permits direct-vent air intake and exhaust runs up to 100 equivalent feet using either PVC, CPVC, Polypropylene or AL29-4C stainless steel vent pipe. A sidewall vent termination kit is shipped standard with every KNIGHT boiler.

### Sidewall Vent Termination



# Lochinvar SMART SYSTEM™

**REFINED DESIGN PUTS MORE CONTROL AND INFORMATION AT YOUR FINGERTIPS**

## Advanced features include:

- MULTI-COLOR GRAPHIC LCD DISPLAY
- NAVIGATION DIAL
- USB PORT
- ABILITY TO CONTROL UP TO THREE DIFFERENT SETPOINT TEMPERATURES
- COMPATIBILITY WITH COPPER-FIN II NON-CONDENSING BOILER TO CREATE A FRONT-END LOADING SYSTEM
- BOILERS WITH DIFFERENT INPUTS CAN BE CASCADED TOGETHER TO MAXIMIZE BOILER PLANT TURNDOWN
- MODBUS CAPABILITY (OPTIONAL)
- DHW MODULATION LIMITING
- DHW NIGHT SETBACK\*
- 0-10 VDC BOILER RATE OUTPUT
- 0-10 VDC SIGNAL TO CONTROL VARIABLE SPEED BOILER PUMP\*
- 0-10 VDC SYSTEM PUMP SIGNAL INPUT\*
- HEAT DEMAND FROM 0-10V INPUT
- INSTALLER CAN PROGRAM NAME AND NUMBER INTO THE BOILER
- INSTALLER ADJUSTABLE FREEZE PROTECTION PARAMETERS
- SEPARATELY ADJUSTABLE SH/DHW SWITCHING TIMES\*
- INSTALLER ACCESS TO BMS AND RAMP DELAY SETTINGS

\*EXCLUSIVE TO LOCHINVAR SMART SYSTEM



## AT-A-GLANCE COLOR CODING



**BLUE SCREEN**  
Normal system operation.



**YELLOW SCREEN**  
Maintenance due - shows the installer's name and number on the display.



**RED SCREEN**  
Lockout mode.

## NEW SELECTABLE CASCADE OPTIONS

When multiple KNIGHT boilers are installed together, the SMART SYSTEM built-in sequencer can be set for "Lead-Lag" cascade or "Efficiency Optimized" cascade operation.

### LEAD-LAG CASCADE

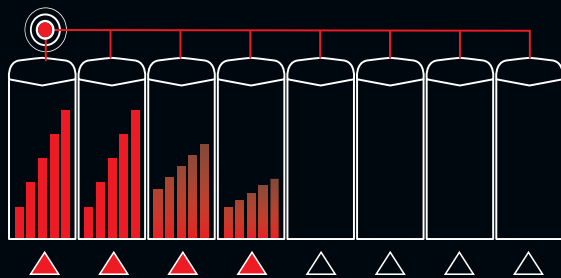

The "lead" boiler modulates with demand to capacity. As demand increases, additional boilers fire and modulate to capacity. This continues, with additional boilers firing and modulating to capacity until all units are operating. Every 24 hours, the SMART SYSTEM automatically shifts the lead boiler role to the next in the sequence, distributing lead-lag runtimes equally.

### EFFICIENCY OPTIMIZED CASCADE

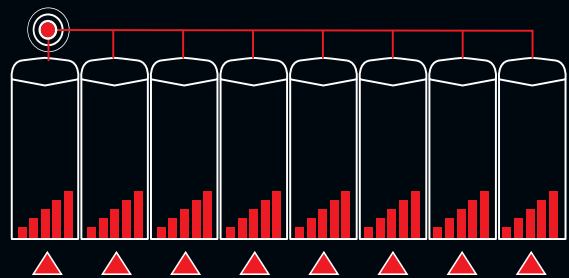

This feature optimizes the modulation capabilities of the Boiler Plant while evenly distributing run time across all cascaded boilers. Every 24 hours the SMART SYSTEM automatically shifts the 1st boiler on role to the next in the sequence, distributing run time equally.

SMART SYSTEM Cascade option allows 2 - 8 boilers to be sequenced.

## 7 FLEXIBLE VENTING OPTIONS

- Direct Vent Sidewall
- Direct Vent Vertical
- Room Air Sidewall
- Room Air Vertical
- Vertical w/Sidewall Air
- Direct Vent Vertical\*
- Direct Vent Sidewall\*

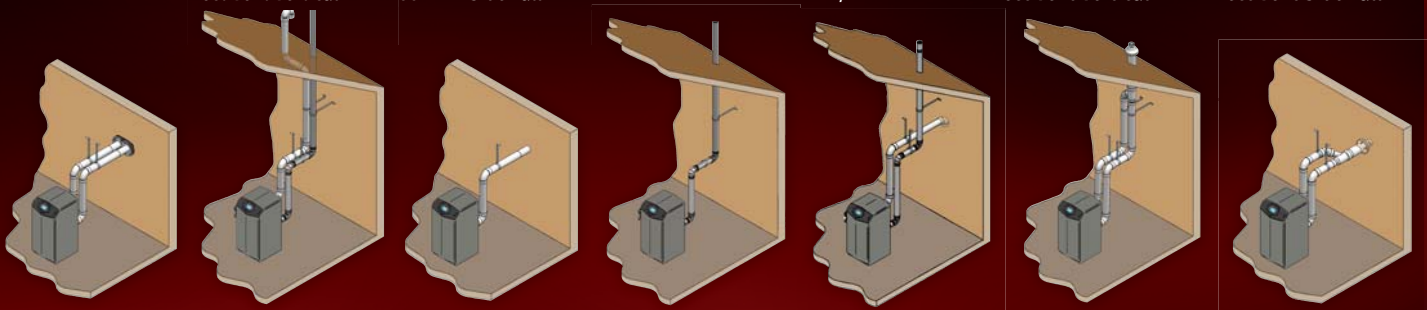

\*Optional Concentric Vent Kit Sold Separately (for 400-601 Models)

# KNIGHT® XL BOILER DIMENSIONS AND SPECIFICATIONS

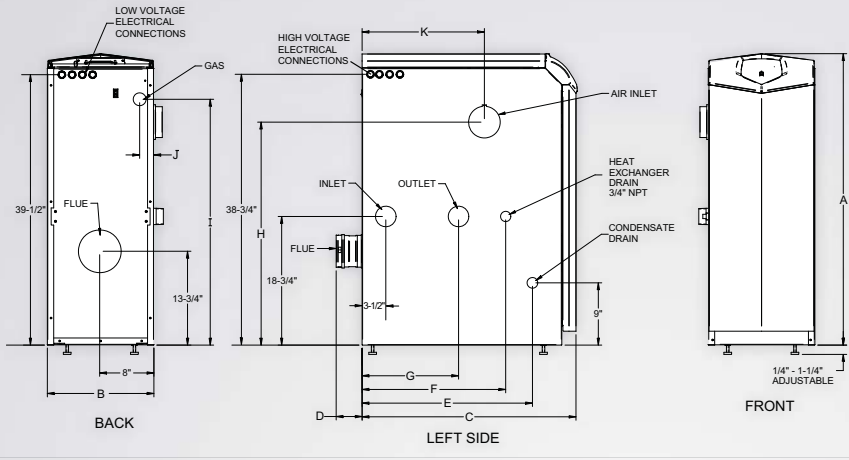

| Model Number Guide |             |              |                 |
|--------------------|-------------|--------------|-----------------|
| KB                 | N           | 701          | M13             |
| Model              | Natural Gas | Btu/hr Input | Firing Controls |

**Knight XL Boiler,**  
**Natural Gas,**  
**700,000 Btu/hr input,**  
**M13 firing controls**

| KNIGHT XL HEATING BOILER |        |     |                    |            |               | DIMENSIONS AND SPECIFICATIONS |         |         |        |         |         |         |         |         |        |         |           |             |           |           |                     |
|--------------------------|--------|-----|--------------------|------------|---------------|-------------------------------|---------|---------|--------|---------|---------|---------|---------|---------|--------|---------|-----------|-------------|-----------|-----------|---------------------|
| Model Number             | Input  |     | Thermal Efficiency | Output MBH | Net I=B=R MBH | A                             | B       | C       | D      | E       | F       | G       | H       | I       | J      | K       | Gas Conn. | Water Conn. | Air Inlet | Vent Size | Shipping Wt. (lbs.) |
|                          | KBN400 | 80  |                    |            |               | 399                           | 94.0%   | 376     | 327    | 42-1/2" | 15-1/2" | 27-3/4" | 3-3/4"  | 20-3/4" | 21"    | 14"     | 34"       | 34"         | 2"        | 18-3/4"   | 1"                  |
| KBN501                   | 100    | 500 | 94.0%              | 470        | 409           | 42-1/2"                       | 15-1/2" | 31-1/2" | 3-3/4" | 25-1/2" | 21"     | 14"     | 32-1/2" | 36"     | 2"     | 18"     | 1"        | 1-1/2"      | 4"        | 4"        | 310                 |
| KBN601                   | 120    | 600 | 94.0%              | 564        | 490           | 42-1/2"                       | 15-1/2" | 36-1/4" | 3-3/4" | 25"     | 21"     | 14"     | 36"     | 32-3/4" | 5-1/2" | 19-1/2" | 1"        | 2"          | 4"        | 4"        | 340                 |
| KBN701                   | 140    | 700 | 94.0%              | 658        | 572           | 42-1/2"                       | 15-1/2" | 40-1/4" | 3-3/4" | 29"     | 23"     | 17"     | 36"     | 32-3/4" | 3-1/4" | 23-1/2" | 1"        | 2"          | 4"        | 6"        | 370                 |
| KBN801                   | 160    | 800 | 94.0%              | 752        | 654           | 42-1/2"                       | 15-1/2" | 45-1/4" | 3-3/4" | 33-1/4" | 23"     | 17"     | 36"     | 32-3/4" | 3-1/4" | 27-3/4" | 1"        | 2"          | 4"        | 6"        | 405                 |

Notes: Indoor installation only. All information subject to change. Change "N" to "L" for LP gas models.

## STANDARD FEATURES

- › **94% Thermal Efficiency**
- › **Modulating Burner with 5:1 Turndown**
  - › Direct-Spark Ignition
  - › Low NOx Operation
  - › Sealed Combustion
  - › Low Gas Pressure Operation
- › **ASME Stainless Steel Heat Exchanger**
  - › ASME Certified, "H" Stamped Gasketless Heat Exchanger
  - › 160 psi Working Pressure
  - › 50 psi ASME Relief Valve
  - › Highly efficient, condensing design
- › **Vertical & Horizontal Direct-Vent**
  - › Category IV venting up to 100 feet
  - › PVC, CPVC, Polypropylene or AL29-4C Venting up to 100 Feet
  - › Factory Supplied Sidewall Vent Termination
- › **Smart System Control**
- › **Other Features**
  - › On/Off Switch
  - › Adjustable High Limit w/ Manual Reset
  - › Automatic Reset High Limit
  - › Flow Switch
  - › Flue Temperature Sensor
  - › Low Air Pressure Switch
  - › Temperature & Pressure Gauge
  - › Adjustable Leveling Legs
  - › Condensate Trap
  - › Zero Clearances to Combustible Material
  - › 10 Year Limited Warranty (See Warranty)

## SMART SYSTEM FEATURES

- › **SMART SYSTEM Digital Operating Control**
  - › Multi-Color Graphic LCD Display w/ Navigation Dial
- › **Three Reset Temperature Inputs with curves for three set point temperature inputs**
- › **Built in Cascading Sequencer for up to 8 Boilers**
  - › Multiple Size Boiler Cascade
  - › Front end loading capability with Copper Fin II
  - › Lead Lag
  - › Efficiency Optimization
- › **Outdoor Reset Control with Outdoor Air Sensor**
- › **Programmable System Efficiency Optimizers**
  - › Night Setback
  - › DHW Night Setback
  - › Anti-Cycling
  - › Outdoor Air Reset Curve
  - › Ramp Delay
  - › Boost Temperature & Time
- › **Three Pump Control**
  - › System Pump With Parameter for Continuous Operation
  - › Boiler Pump With Variable Speed Pump Control\*
  - › Domestic Hot Water Pump
- › **Domestic Hot Water Prioritization**
  - › DHW tank piped with priority in the boiler loop
  - › DHW tank piped as a zone in the system with the pumps controlled by the Smart System
  - › DHW Modulation Limiting
  - › Separately Adjustable SH/DHW Switching Times\*
- › **Building Management System Integration**
  - › 0-10 VDC Input to Control Modulation or Set Point
  - › 0-10 VDC Input Signal from Variable Speed System Pump\*
  - › 0-10 VDC Modulation Rate Output
  - › 0-10 VDC Input to Enable/Disable call for heat
  - › Access to BMS Settings through Display

- › **High Voltage Terminal Strip**
    - › 120 VAC / 60 Hertz / 1 Phase Power Supply
    - › Three sets of Pump Contacts with Pump Relays
  - › **Low Voltage Terminal Strip**
    - › 24 VAC Device Relay
    - › Proving Switch Contacts
    - › Flow Switch Contacts
    - › Alarm on Any Failure Contacts
    - › Runtime Contacts
    - › DHW Thermostat Contacts
    - › 3 Space Heat Thermostat Contacts
    - › System Sensor Contacts
    - › DHW Tank Sensor Contacts
    - › Outdoor Air Sensor Contacts
    - › Cascade Contacts
    - › 0-10 VDC BMS External Control Contact
    - › 0-10 VDC Boiler Rate Output Contacts
    - › 0-10 VDC Variable Speed System Pump Signal Input
    - › 0-10 VDC Signal to Control Variable Speed Boiler Pump
    - › Modbus Contacts
  - › **Time Clock**
  - › **Data Logging**
    - › Hours Running, Space Heating
    - › Hours Running, Domestic Hot Water
    - › Ignition Attempts
    - › Last 10 Lockouts
  - › **Other Features**
    - › Low Water Flow Safety Control & Indication
    - › Password Security
    - › Inlet & Outlet Temperature Readout
    - › Customizable Freeze Protection Parameters
    - › Custom Maintenance Reminder with Contractor Info
- \*Exclusive feature, available only from Lochinvar*

## FIRING CODES

- › M9 Standard Construction
- › M7 California Code
- › M13 CSD1 / FM / GE Gap (KB501-KB801)

## OPTIONAL EQUIPMENT

- › Alarm Bell
- › Condensate Neutralization Kit
- › Concentric Vent Kit (KB400-KB601)
- › BMS Gateway to LON or BacNet
- › High & Low Gas Pressure Switches w/ Manual Reset (KB501-KB801)

- › MODBUS Communication
- › Multi Temperature Loop Control
- › Low Water Cutoff w/ Manual Reset & Test
- › Boiler Circulation Pump
- › SMART SYSTEM PC Software
- › Stainless Steel Vent Kits (KB701-KB801)
- › Stack Frame



Lochinvar, LLC  
 300 Maddox Simpson Parkway  
 Lebanon, Tennessee 37090  
 P: 615-889-8900 / F: 615-547-1000  
[www.Lochinvar.com](http://www.Lochinvar.com)



Registered Under  
 U.S. Patents  
 #7824178 and  
 7506617

